

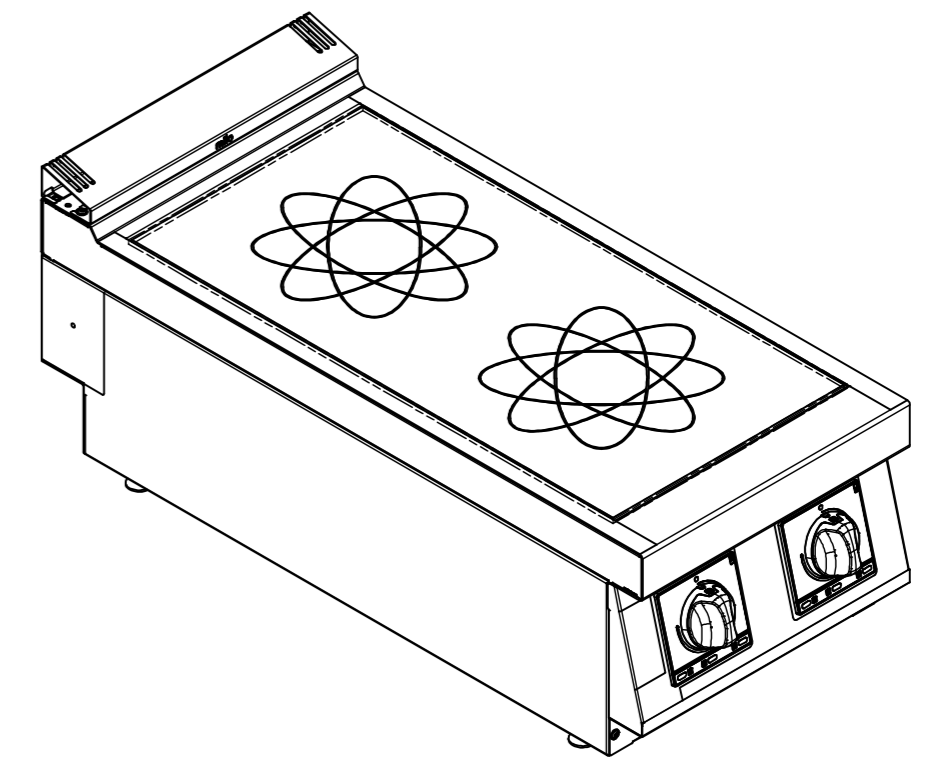

SEZIONE A - A

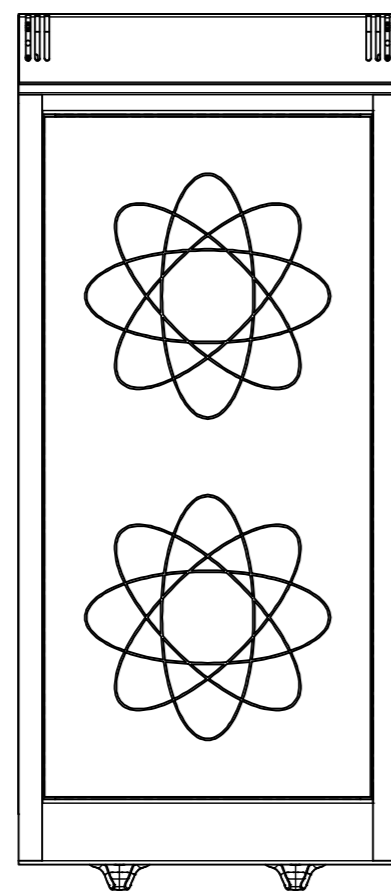
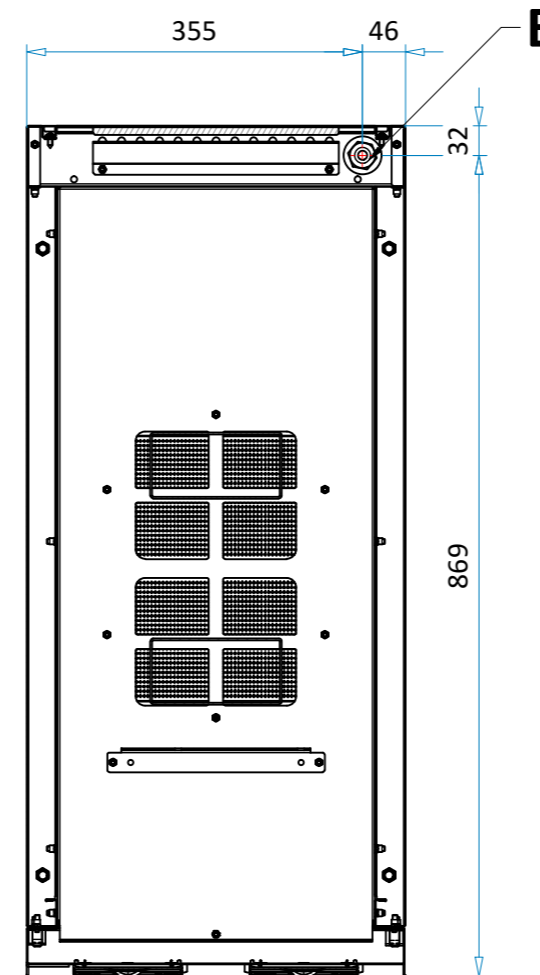

REV.	DESCRIZIONE	APPROVATO DA	DATA
00	Emesso	VLADUT.IACOMI	28/02/2025
PROGETTISTA	DANILO.GIAMMARUCO	DATA CREAZIONE	
DISEGNATORE	DANILO.GIAMMARUCO	ULTIMA MOD.	01/08/2023
MATERIALE			
		FOGLIO	SCALA
		A3	1 : 8
		TOLLERANZE GENERALI	PESO IN KG
		ISO 2768-1 mK	21.84
CODICE	REV.	DESCRIZIONE	
11590006	00	M9TCE2I CUCINA IND. ELE 2Z.	

A		B		C		D		E		F		G		H		I		L		M		N			
ELENCO PARTI																									
N°	QTÀ	CODICE		REV.	DESCRIZIONE (ITA)	DESCRIPTION (EN)						BESCHREIBUNG (DE)						DESCRIPTION (FR)				DESCRIPCIÓN (ES)			
1	1	60200928		04	COPERTURA FORO PIANO MILO - 400																				
2	16	80300259		00	VITE TB TX25 FLANG.A2 INOX M5X12																				
3	4	829541		00	MANIGLIETTE FE/ZN 9X34XM5 CRUS																				
4	1	20100439		00	ASS. MANTELLO IND S90 - 400 TOP																				
5	1	60200985		03	SCHIENA RINFORZATA 400 TOP MILO																				
6	4	80300260		00	VITE AUTOFIL. DIN 7981/TX 4,8X13 ZNC																				
7	1	20100049		04	ASS. CRUSCOTTO CIE/CVE PIASTRA 400																				
8	1	80300126		01	GHIERA CUCINA 1-9 MILO POSTERIORE																				
9	1	80300127		01	GHIERA CUCINA 1-9 MILO ANTERIORE																				
10	2	80300100		01	MANOPOLA MILO D.6 ELE																				
11	8	80300258		00	INSERTO M5 ESAGONO ZINCATO																				
12	1	20300010		00	IMBALLO 400 MILO TOP																				
13	1	849637		00	ADESIVO TRIANGOLARE 400V																				
14	1	80300339		02	PIANO ASS.IND. 400X900 MILO 2X5KW																				
15	1	60201339		00	GUIDA FILTRI INDUZIONE - MILO																				
16	1	80300138		00	LOGO OFFCAR 36X36 METAL THIN LABEL																				
17	2	80300213		00	MLV SEG.LUM.LED VERDE 12V																				
18	1	80300588		00	VOLAN. DI SERRAGGIO A SEZIONE PIENA																				
19	1	60201097		04	STAFFA SUPPORTO TELERUTTORE																				
20	2	60201413		01	RIDUZIONE PER PRESSACAVO PG16																				
21	1	849509		00	PRESSACAVO+DADO CEMBRE PG16																				
22	1	849031		00	CAVO ALIMENT. 5X2,5X3,5MT H07RN-F																				
23	1	20300024		00	KIT GIUNZIONE MACCHINE																				
24	1	60201837		00	CHIUS. ANTERIORE MACCHINE TOP 400																				

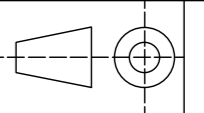
PROGETTISTA	DANILO.GIAMMARUCO		DATA CREAZIONE		
DISEGNATORE	DANILO.GIAMMARUCO		ULTIMA MOD.	01/08/2023	
MATERIALE					
		FOGLIO	SCALA		
		A3	1 : 8	TOLLERANZE GENERALI ISO 2768-1 mK	PESO IN KG 21.84
CODICE	REV.	DESCRIZIONE			
11590006	00	M9TCE2I CUCINA IND. ELE 2Z.			

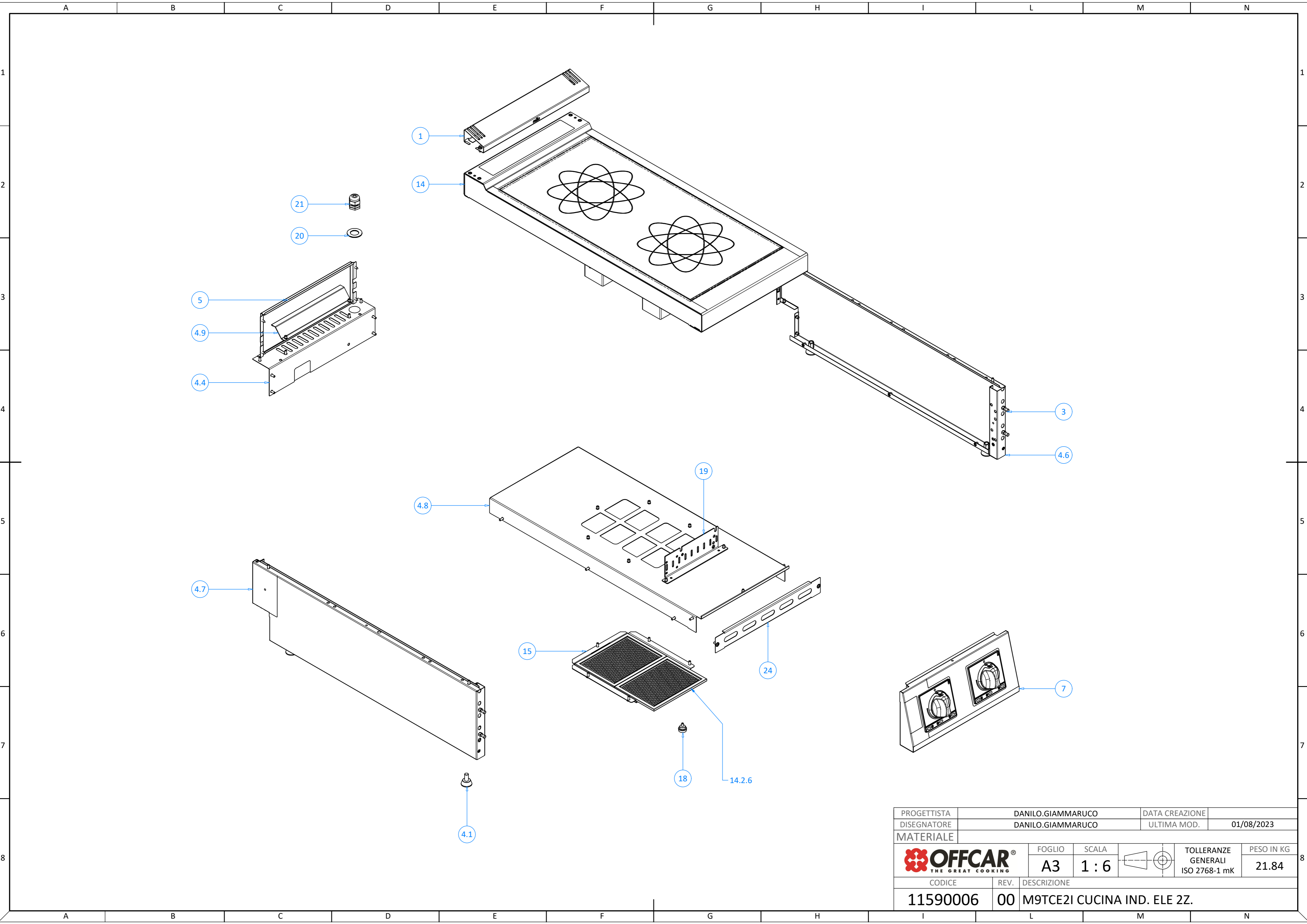

PROGETTISTA	DANILO.GIAMMARUCO		DATA CREAZIONE	01/08/2023	
DISEGNATORE	DANILO.GIAMMARUCO		ULTIMA MOD.	01/08/2023	
MATERIALE					
		FOGLIO	SCALA		PESO IN KG
		A3	1 : 6		21.84
CODICE	REV.	DESCRIZIONE			
11590006	00	M9TCE2I CUCINA IND. ELE 2Z.			

A		B		C		D		E		F		G		H		I		L		M		N			
ELENCO PARTI																									
N°	QTÀ	CODICE		REV.	DESCRIZIONE (ITA)	DESCRIPTION (EN)						BESCHREIBUNG (DE)						DESCRIPTION (FR)				DESCRIPCIÓN (ES)			
1	1	60200928		04	COPERTURA FORO PIANO MILO - 400																				
3	4	829541		00	MANIGLIETTE FE/ZN 9X34XM5 CRUS																				
4.1	4	844345		00	PIEDINO REG.POLI.NERO 30XM10 40152N																				
4.4	1	60200984		04	ANGOL. CHIUSURA POST. TOP S7 400																				
4.6	1	60201342		06	FIANCO DX SERIE 90 TOP - MILO																				
4.7	1	60201343		06	FIANCO SX SERIE 90 TOP - MILO																				
4.8	1	60201364		03	PROT. INFER. IND TOP - S9 400																				
4.9	1	60201755		00	DEFLET ANTIACQUA TOP 400 - MILO																				
5	1	60200985		03	SCHIENA RINFORZATA 400 TOP MILO																				
7	1	20100049		04	ASS. CRUSCOTTO CIE/CVE PIASTRA 400																				
8	1	80300126		01	GHIERA CUCINA 1-9 MILO POSTERIORE																				
9	1	80300127		01	GHIERA CUCINA 1-9 MILO ANTERIORE																				
10	2	80300100		01	MANOPOLA MILO D.6 ELE																				
14	1	80300339		02	PIANO ASS.IND. 400X900 MILO 2X5KW																				
14.2.6	2	843302		00	KIT FILTRO PER INDUZIONE 340.195																				
15	1	60201339		00	GUIDA FILTRI INDUZIONE - MILO																				
18	1	80300588		00	VOLAN. DI SERRAGGIO A SEZIONE PIENA																				
19	1	60201097		04	STAFFA SUPPORTO TELERUTTORE																				
20	2	60201413		01	RIDUZIONE PER PRESSACAVO PG16																				
21	1	849509		00	PRESSACAVO+DADO CEMBRE PG16																				
24	1	60201837		00	CHIUS. ANTERIORE MACCHINE TOP 400																				

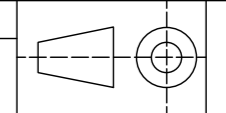
PROGETTISTA	DANILO.GIAMMARUCO		DATA CREAZIONE		
DISEGNATORE	DANILO.GIAMMARUCO		ULTIMA MOD.	01/08/2023	
MATERIALE					
		FOGLIO	SCALA		
		A3	1 : 8	TOLLERANZE GENERALI ISO 2768-1 mK	PESO IN KG 21.84
CODICE	REV.	DESCRIZIONE			
11590006	00	M9TCE2I CUCINA IND. ELE 2Z.			

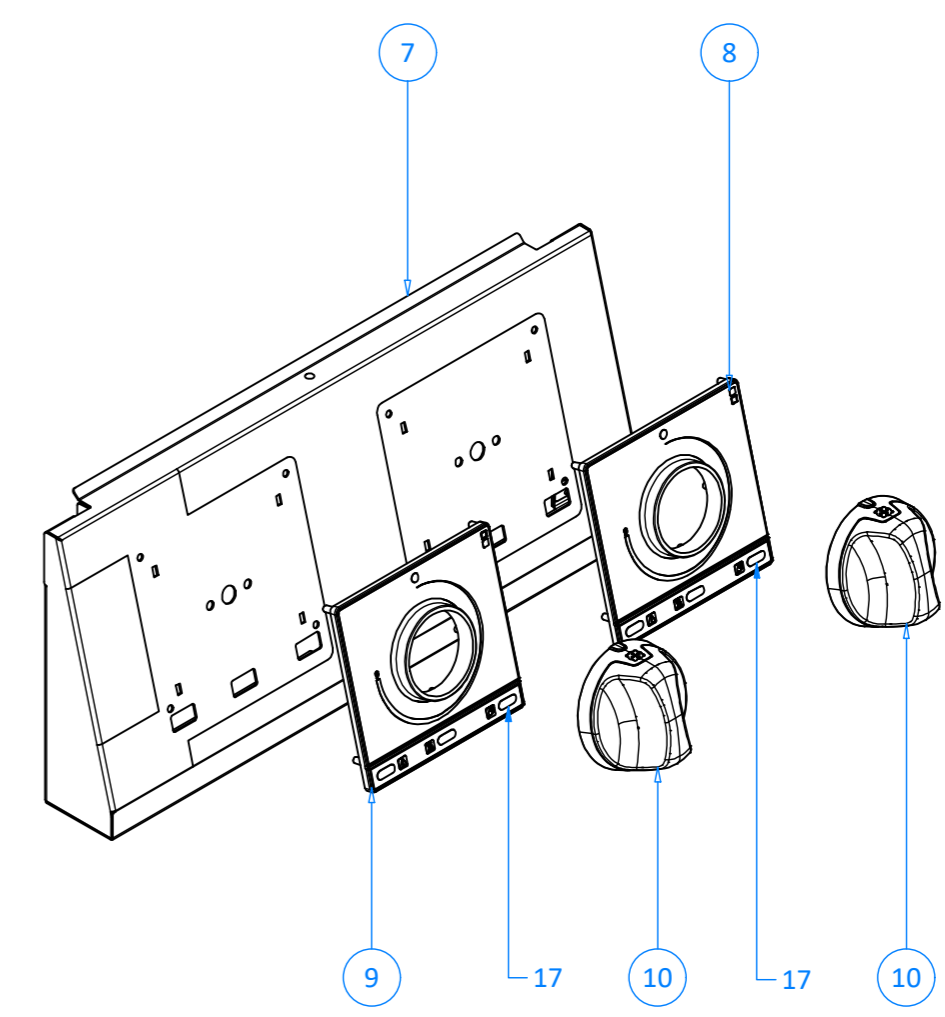
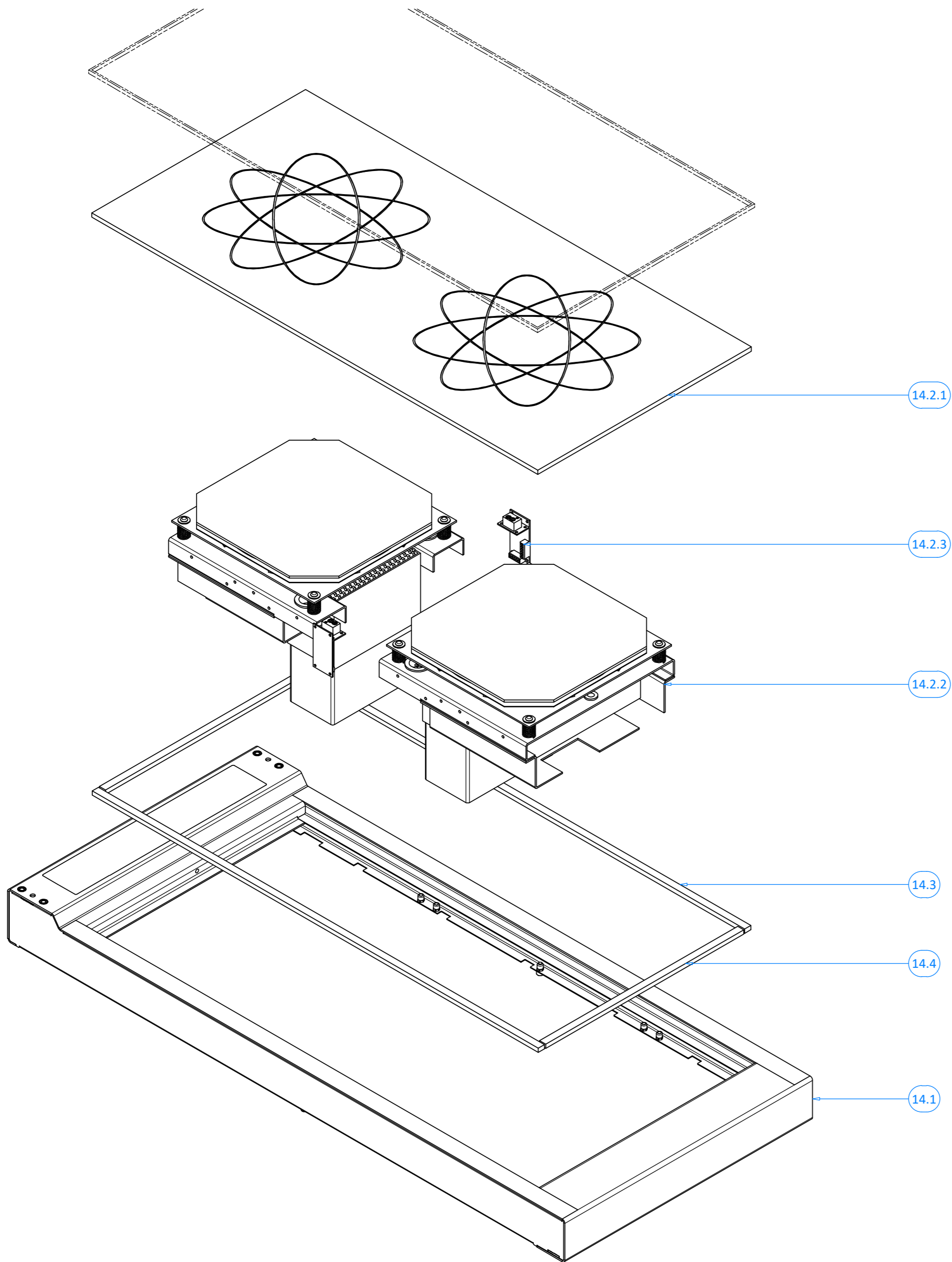

PROGETTISTA	DANILO.GIAMMARUCO		DATA CREAZIONE		
DISEGNATORE	DANILO.GIAMMARUCO		ULTIMA MOD.	01/08/2023	
MATERIALE					
 <b>OFFCAR</b> <small>THE GREAT COOKING</small>		FOGLIO	SCALA		TOLLERANZE GENERALI ISO 2768-1 mK
		A3	1 : 4	PESO IN KG 21.84	
CODICE	REV.	DESCRIZIONE			
11590006	00	M9TCE2I CUCINA IND. ELE 2Z.			

A		B		C		D		E		F		G		H		I		L		M		N	
N°	QTÀ	CODICE		REV.	DESCRIZIONE (ITA)	DESCRIPTION (EN)						BESCHREIBUNG (DE)				DESCRIPTION (FR)				DESCRIPCIÓN (ES)			
7	1	20100049		04	ASS. CRUSCOTTO CIE/CVE PIASTRA 400																		
8	1	80300126		01	GHIERA CUCINA 1-9 MILO POSTERIORE																		
9	1	80300127		01	GHIERA CUCINA 1-9 MILO ANTERIORE																		
10	2	80300100		01	MANOPOLA MILO D.6 ELE																		
14.1	1	20200131		06	SAL. TELAIO 40X90 VTC/IND MILO																		
14.2.1	1	844812		00	VETRO IND. 6MM (2F S.900) 300.210.3																		
14.2.2	2	843829		00	GENERATORE 5KW S.900 340.204																		
14.2.3	2	843847		00	DISPLAY COMP.DI SCHEDA LEED.340.314																		
14.2.4	2	843808		00	SENSORE TEMP.X MINIBIMP 340.184																		
14.2.5	2	843842		00	FUSIBILE SI T20A 250V 340.224																		
14.2.6	2	843302		00	KIT FILTRO PER INDUZIONE 340.195																		
14.3	2	80300492		00	GUARNIZIONE VETRO LUNGA S90 IND/VTC																		
14.4	2	80300491		00	GUARNIZIONE VETRO CORTA IND/VTC																		
17	2	80300213		00	MLV SEG.LUM.LED VERDE 12V																		
22	1	849031		00	CAVO ALIMENT. 5X2,5X3,5MT H07RN-F																		

ELENCO PARTI

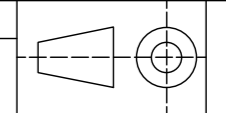
PROGETTISTA	DANILO.GIAMMARUCO		DATA CREAZIONE		
DISEGNATORE	DANILO.GIAMMARUCO		ULTIMA MOD.	01/08/2023	
MATERIALE					
		FOGLIO	SCALA		
		A3	1 : 8	TOLLERANZE GENERALI ISO 2768-1 mK	
PESO IN KG		21.84			
CODICE	REV.	DESCRIZIONE			
11590006	00	M9TCE2I CUCINA IND. ELE 2Z.			