

SEZIONE A - A

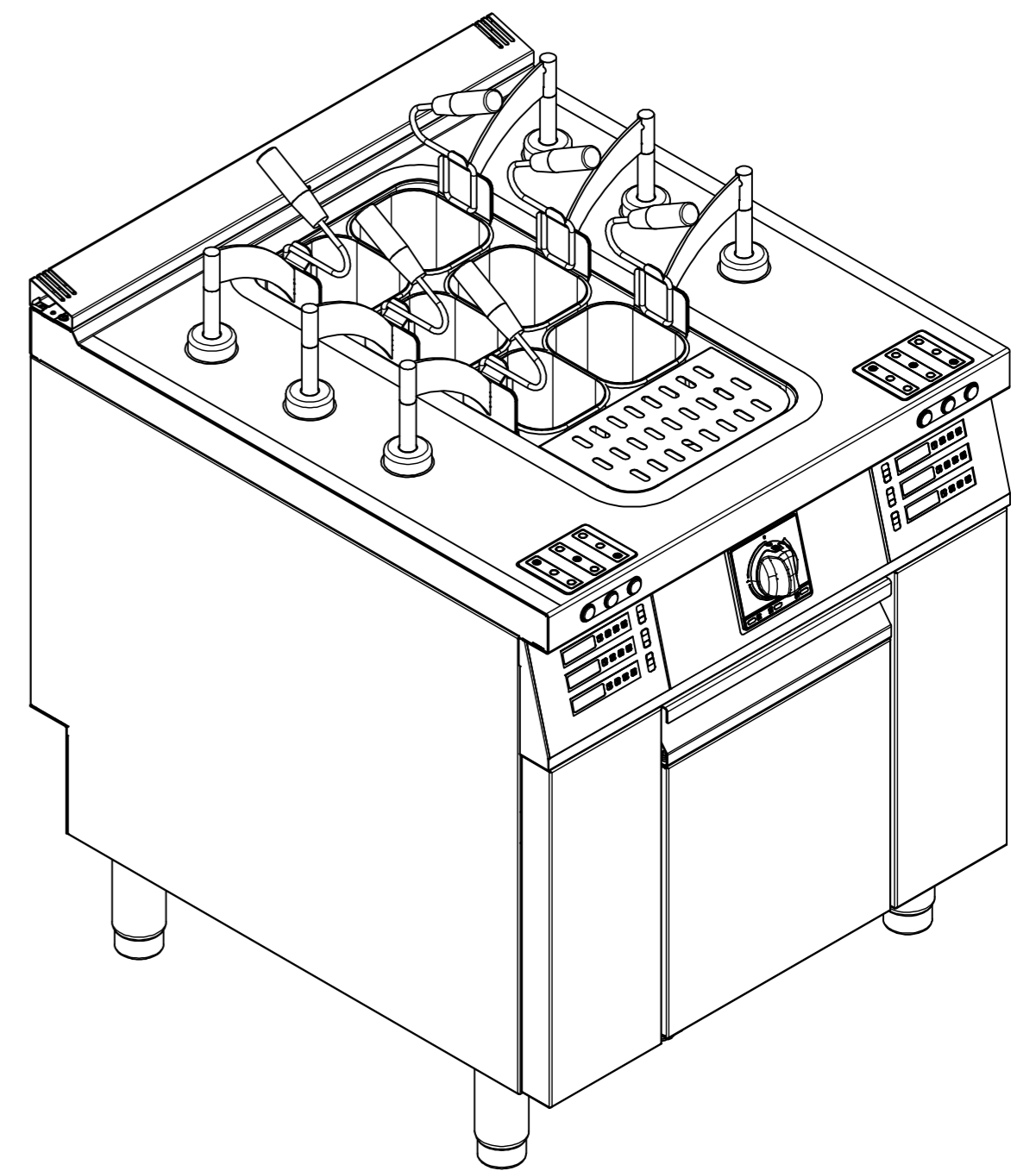
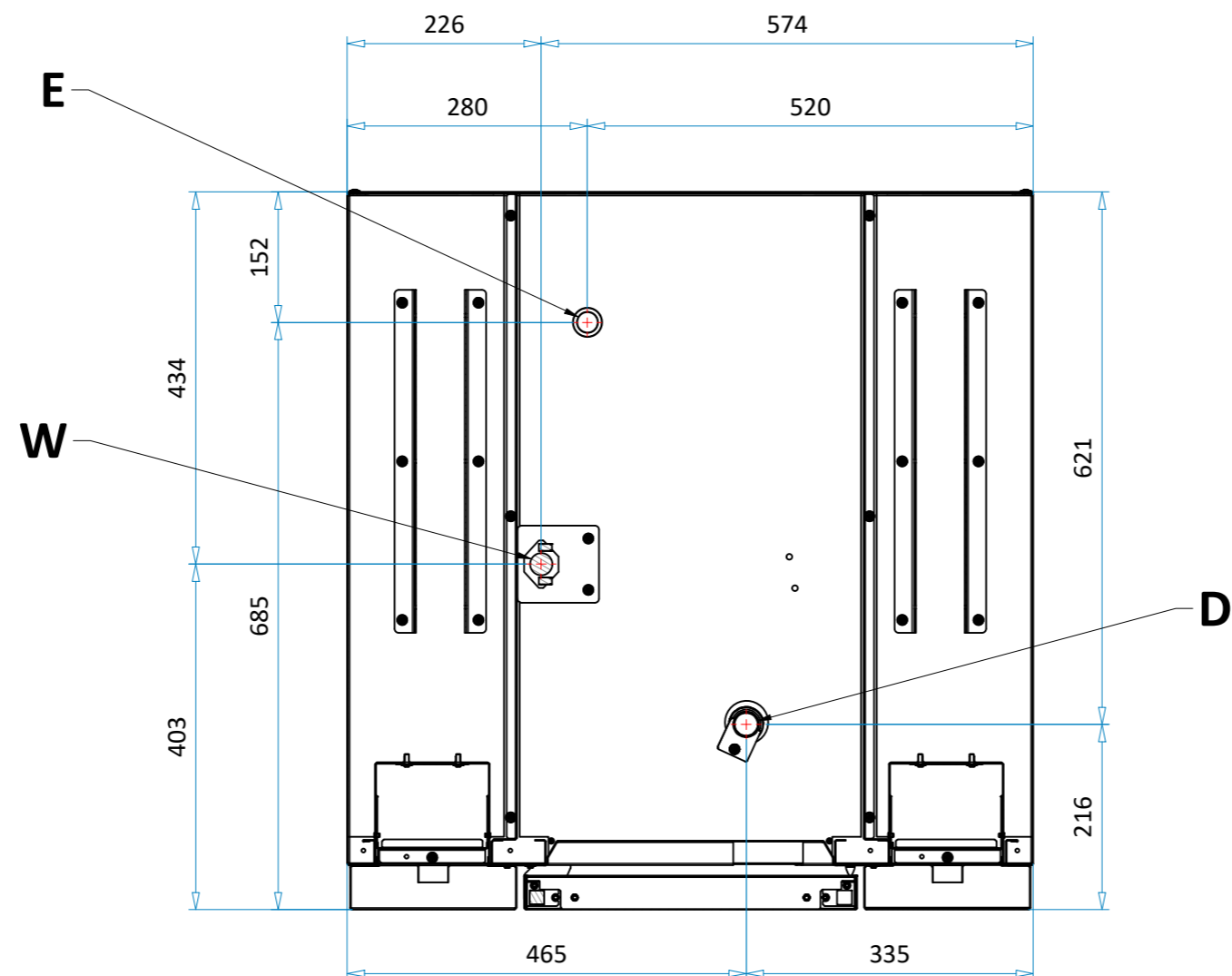
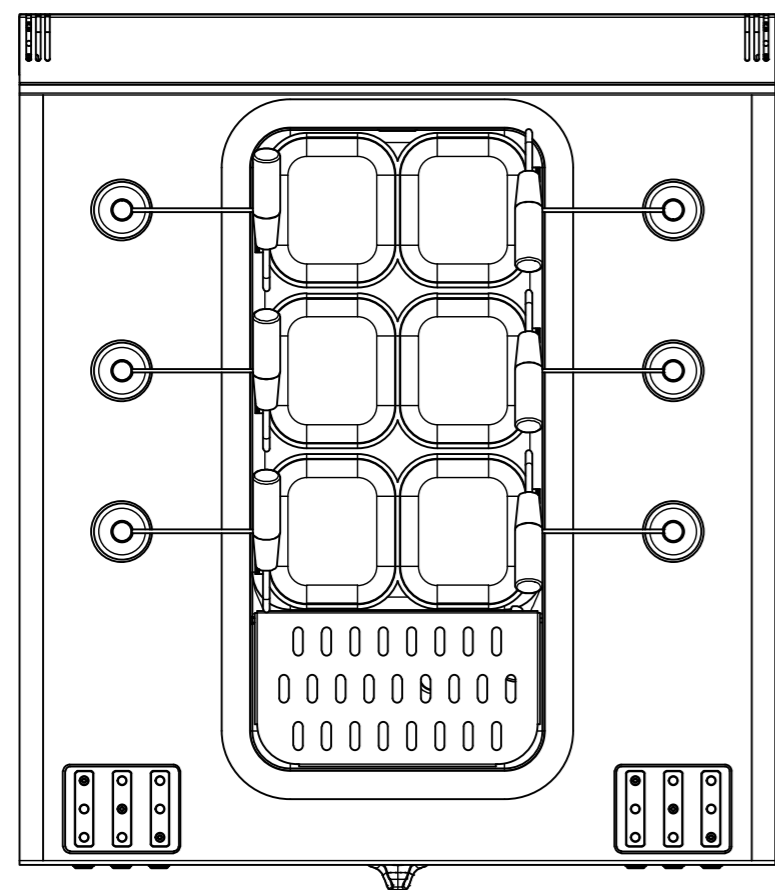

REV.	DESCRIZIONE	APPROVATO DA	DATA
00	Emesso	VLADUT.IACOMI	21/02/2025
PROGETTO DI:		DANILO.GIAMMARUCO	
DISEGNATO DA:		DANILO.GIAMMARUCO	
MATERIALE			
		FOGLIO A2	SCALA 1 : 8
CODICE		REV.	DESCRIZIONE
11391002		00	MDPE45CL2A PASTA CORNER ELE 1V. 45L
TOLLERANZE GENERALI ISO 2768-1 mK			PESO IN KG 158.3

A		B		C		D		E		F		G		H		I		L		M		N							
ELENCO PARTI																													
N°	QTÀ	CODICE		REV.	DESCRIZIONE (ITA)	DESCRIPTION (EN)						BESCHREIBUNG (DE)						DESCRIPTION (FR)						DESCRIPCIÓN (ES)					
1	1	20100506		00	ASS. PREAS. MANTELLO PASTACORNER 90																								
2	6	841310		01	BOCCOLA CENTRAGGIO X BARRE ALZAC.																								
3	6	834005		03	ASTA DI SOLLEVAM. X ALZAC. CUOCIP.																								
4	6	850104		00	ATTUATORE UL CORSA 210MM 6815238																								
5	6	834007		06	PERNO FISSAGGIO ASTA SOLLEVAMENTO																								
6	6	4200366		01	PROTEZ. ANTIGOCCIOLAM. X ATTUATORI																								
7	6	4200365		05	SUPPORTO ANTIROTAZ. X ALZACESTI																								
8	12	851130		00	COPIGLIA INOX "R" 2165F D.2																								
9	6	862085		00	ANELLO RASCHIATORE SAB20 ALZACESTI																								
10	6	4200370		04	SUPP.ALZACESTI.CUOCIP.S.700/980S																								
11	6	852946		00	PERNO DA INNESTO INOX A4 8X74																								
12	6	852944		00	PERNO DA INNESTO INOX A4 8X54																								
13	22	80300258		00	INSERTO M5 ESAGONO ZINCATO																								
14	13	852053		00	VITE TE INOX M5X40 DIN933																								
15	5	853790		00	ROSETTA INOX M5 5X10 DIN 125																								
16	8	829541		00	MANIGLIETTE FE/ZN 9X34XM5 CRUS																								
17	1	60200314		10	SCHIENA RINFORZATA 800																								
18	1	60200767		07	ANGOL. CHIUSURA POST. FOR. 800 MILO																								
19	1	20100224		02	ASS. SCATOLA ELETTRICA CUOCIPASTA																								
20	1	80300128		00	GHIERA CUOCIPASTA MILO ELE																								
21	1	80300100		01	MANOPOLA MILO D.6 ELE																								
22	1	20100537		00	ASS. CRUSC. PASTACORNER S90 + ETIC.																								
23	1	20100087		03	ASS. ASS. PORTA 1/2 CON MANIGLIA MILO																								
24	2	852591		00	VITE TPSCE INOX M5*16 DIN7991																								
25	2	20100194		01	ASS. PANN. ANT ALZAC. PASTACORNER																								
26	1	60200425		01	FINITO CERNIERA SUP. PORTA MILO																								
27	1	20100200		02	ASS. GRUPPO SCARICO ACQUA CPG MILO																								
28	2	830801		00	FASCETTA ABA ALUZINK DIAM.32-44																								
29	2	60200748		01	CHIUSURA SCATOLA SCHEDE ALZAC. MILO																								
30	2	80300064		00	ANTIVIB. RIF. DVA.6-10-10-M5-12-40 ELESA																								
31	6	862326		00	PULSANTE INOX MONOPOLO IP40 10A																								
32	1	20400088		02	ASS. TELAIO ALZ. SUP.80X90 PASTACOR																								
33	1	60200829		00	GRIGLIETTA FORATA CUOC.PIEGATA MILO																								
34	1	853655		00	DADO INOX M5 AUTOBLOCCANTE																								
35	1	80300053		00	DADO M8 CIECO CON CALOTTA DIN 1587																								
36	1	80300057		00	MANIGLIA ELESA RIF. 21602																								
37	1	60200852		01	DEFLETTORE ANTIACQUA X 800 - MILO																								
38	1	20100225		04	ASS. CARICO ACQUA AUTOMATICO MILO																								
39	1	80300220		00	RACC RAPIDO MASCHIO 3/8 D. 10																								
40	1	80300471		00	DADO FLANGIATO OTTONE 3/8																								

PROGETTO DI:	DANILO.GIAMMARUCO				
DISEGNATO DA:	DANILO.GIAMMARUCO				
MATERIALE					
	FOGLIO	SCALA		TOLLERANZE GENERALI ISO 2768-1 mK	PESO IN KG
	A2	1 : 8			158.3
CODICE	REV.	DESCRIZIONE			
11391002	00	MDPE45CL2A PASTA CORNER ELE 1V. 45L			

A		B		C		D		E		F		G		H		I		L		M		N		
ELENCO PARTI																								
N°	QTÀ	CODICE		REV.	DESCRIZIONE (ITA)				DESCRIPTION (EN)				BESCHREIBUNG (DE)				DESCRIPTION (FR)				DESCRIPCIÓN (ES)			
41	1	80300223		00	GUARNIZIONE EROGATORE CPG MILO																			
42	1	829831		00	MANICOTTO INOX DA 3/8"																			
43	1	60200854		01	TUBO PTFE D.10 EROG. PASTACORNER																			
44	6	861142		00	CESTO CUOCIPASTA NERO GN1/6DX H215																			
45	1	60201475		00	TUBO SCARICO CUOCIPASTA D.40X650																			
46	82	80300259		00	VITE TB TX25 FLANG.A2 INOX M5X12																			
47	1	20400052		03	SAL. EROGATORE H2O CPG-PASTACORNER																			
48	2	855575		01	INSERTO DEF. INOX RASO M5 F L=11,5																			
49	2	829551		04	PERNO INOX D.5X35 GRIGLIETTA CUOCIP																			
50	1	20300004		00	IMBALLO 800 MILO																			
51	1	60201246		02	COPERTURA FORO PIANO MILO - 800																			
52	3	819136		00	BOCCOLA PASSAGGIO CAVI LEGNB																			
53	1	20100392		06	ASS. PARATIA CPE/PASTACORNER MILO																			
54	1	4200515		06	RINFORZO RESIST. CUOC. ELETTRICO																			
55	2	4200514		05	SUPPORTO ANT./POST. RESISTENZE CPE																			
56	7	853659		00	DADO INOX M5 FINTA RONDDL. DIN																			
57	6	80300260		00	VITE AUTOFIL. DIN 7981/TX 4,8X13 ZNC																			
58	1	20200087		02	SAL. ASTA PROLUNGA CON BUSSOLA CPG																			
59	1	80300052		03	PERNO MANIGLIA SCARICO FRIG. MILO																			
60	1	80300138		00	LOGO OFFCAR 36X36 METAL THIN LABEL																			
61	2	20100509		00	ASS. OMEGA SUPP. ATTUAT. ALZAC S.90																			
62	2	80300554		00	ETICHETTA CONT ALZAC PASTACORNER S9																			
63	1	20100271		02	ASS. CERNIERA PORTA + STAFFA + VIT.																			
64	1	60200868		01	TUBO PTFE D.10 CARICO AUTO CPG																			
65	1	20100626		00	ASS. KIT SCAT. ELETTRICHE MDPE MILO																			
66	6	856001		00	SCHEDA POTENZA F1 24VAC CON CONNETT																			
67	1	80300309		00	RACCORDO RAPIDO 90° 3/8 D.10																			
68	2	60201762		00	CHIUS PULSAN ALZAC PASTACORNER S90																			
69	1	60201766		00	PIASTRINA EV PASTACORNER																			
70	1	835960		00	ELETTRIVALVOLA 2 VIE CODOLO 10MM UL																			
71	1	992568		00	"RACCORDO INTERMEDIO ""T"" HUT1010W"																			
72	1	992570		00	GOMITO CODOLO 10X10 HLJ1010W																			
73	1	80300619		01	COIBENTAZIONE VASCA CPE S9																			
74	1	60200872		02	ANGOL. FISS. CARICO ACQUA AUTO																			
75	1	20300024		00	KIT GIUNZIONE MACCHINE																			
76	2	80300005		01	PERNO INOX D.5X15 CERNIERA POR																			
77	2	843860		01	RESISTENZA ANGOL.4500W 400V MORS.UL																			



PROGETTO DI:		DANILO.GIAMMARUCO					
DISEGNATO DA:		DANILO.GIAMMARUCO					
MATERIALE							
		FOGLIO	SCALA			TOLLERANZE GENERALI	PESO IN KG
		A2	1 : 8			ISO 2768-1 mK	158.3
CODICE	REV.	DESCRIZIONE					
11391002	00	MDPE45CL2A PASTA CORNER ELE 1V. 45L					

A B C D E F G H I L M N

1
2
3
4
5
6
7
8

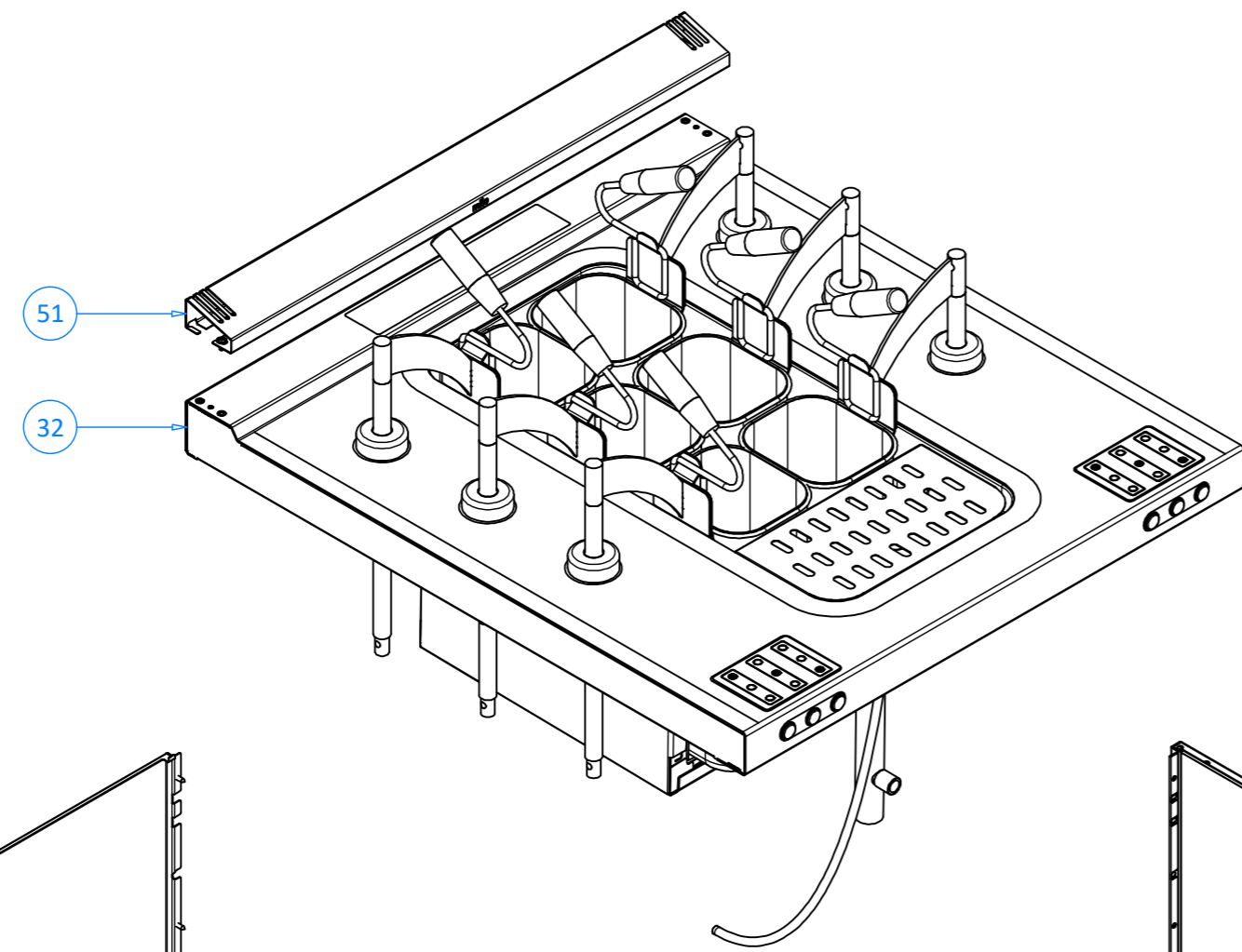

PARTICOLARE C

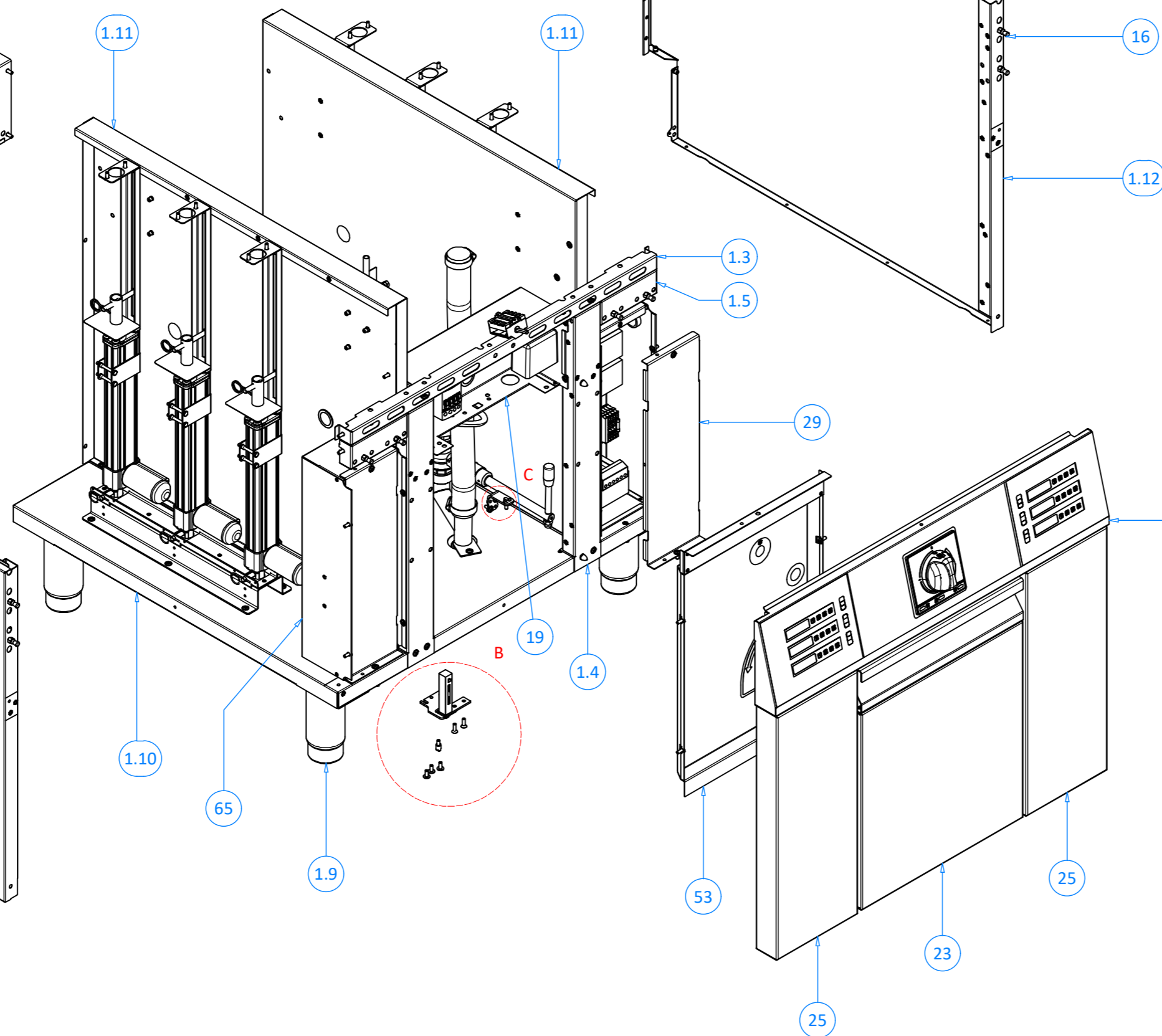
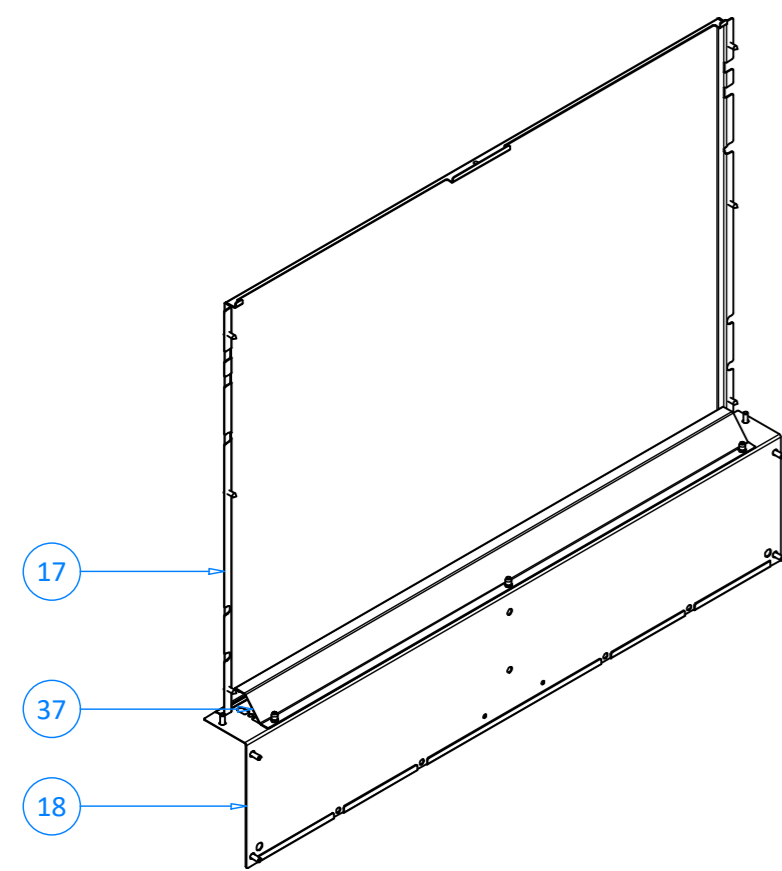
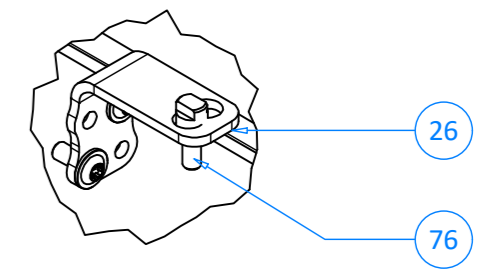

PARTICOLARE B

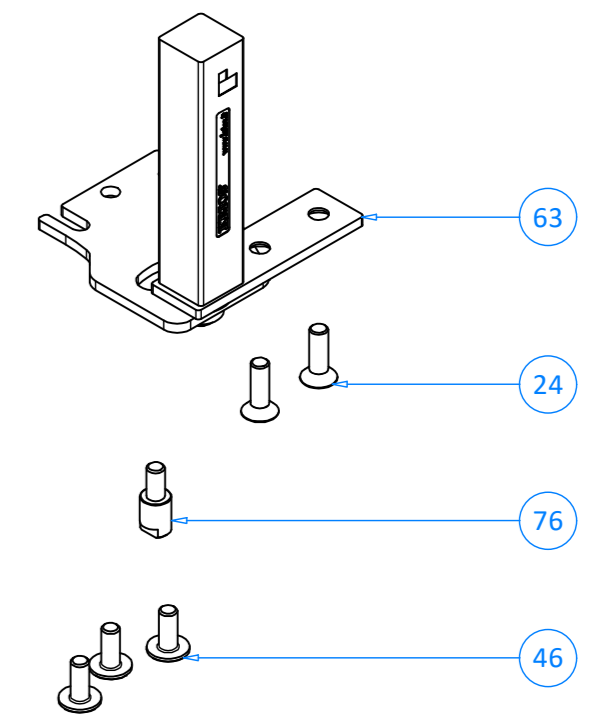

PROGETTO DI:		DANILO.GIAMMARUCO			
DISEGNATO DA:		DANILO.GIAMMARUCO			
MATERIALE					
OFFCAR THE GREAT COOKING		FOGLIO	SCALA	TOLLERANZE GENERALI ISO 2768-1 mK	PESO IN KG 158.3
		A2	1 : 8		
CODICE	REV.	DESCRIZIONE			
11391002	00	MDPE45CL2A PASTA CORNER ELE 1V. 45L			

A B C D E F G H I L M N

A		B		C		D		E		F		G		H		I		L		M		N							
ELENCO PARTI																													
N°	QTÀ	CODICE		REV.	DESCRIZIONE (ITA)	DESCRIPTION (EN)						BESCHREIBUNG (DE)						DESCRIPTION (FR)						DESCRIPCIÓN (ES)					
1.3	1	60200315		02	TRAVERSA RINFORZO MANTELLO 800																								
1.4	2	60200721		04	TRAVERSO MEDIANO MILO																								
1.5	2	60200741		02	SUPPORTO MANIGLIETTE PASTACORNER																								
1.9	4	80300255		00	PIEDE 2" INOX 150 - 210																								
1.10	1	60201588		01	BASAMENTO PASTACORNER S.90																								
1.11	2	60201589		00	PROT. ANTIACQUA PASTACORNER 90 MILO																								
1.12	1	60200430		12	FIANCO DX SERIE 90 - MILO																								
1.13	1	60200431		13	FIANCO SX SERIE 90 - MILO																								
17	1	60200314		10	SCHIENA RINFORZATA 800																								
18	1	60200767		07	ANGOL. CHIUSURA POST. FOR. 800 MILO																								
19	1	20100224		02	ASS. SCATOLA ELETTRICA CUOCIPASTA																								
22	1	20100537		00	ASS. CRUSC. PASTACORNER S90 + ETIC.																								
23	1	20100087		03	ASS. ASS. PORTA 1/2 CON MANIGLIA MILO																								
24	2	852591		00	VITE TPSCE INOX M5*16 DIN7991																								
25	2	20100194		01	ASS. PANN. ANT ALZAC. PASTACORNER																								
26	1	60200425		01	FINITO CERNIERA SUP. PORTA MILO																								
29	2	60200748		01	CHIUSURA SCATOLA SCHEDE ALZAC. MILO																								
32	1	20400088		02	ASS. TELAIO ALZ. SUP.80X90 PASTACOR																								
37	1	60200852		01	DEFLETTORE ANTIACQUA X 800 - MILO																								
46	82	80300259		00	VITE TB TX25 FLANG.A2 INOX M5X12																								
51	1	60201246		02	COPERTURA FORO PIANO MILO - 800																								
53	1	20100392		06	ASS. PARATIA CPE/PASTACORNER MILO																								
63	1	20100271		02	ASS. CERNIERA PORTA + STAFFA + VIT.																								
65	1	20100626		00	ASS. KIT SCAT. ELETTRICHE MDPE MILO																								
76	2	80300005		01	PERNO INOX D.5X15 CERNIERA POR																								

PROGETTO DI:	DANILO.GIAMMARUCO				
DISEGNATO DA:	DANILO.GIAMMARUCO				
MATERIALE					
	FOGLIO	SCALA		TOLLERANZE GENERALI ISO 2768-1 mK	PESO IN KG
	A2	1 : 8			158.3
CODICE	REV.	DESCRIZIONE			
11391002	00	MDPE45CL2A PASTA CORNER ELE 1V. 45L			

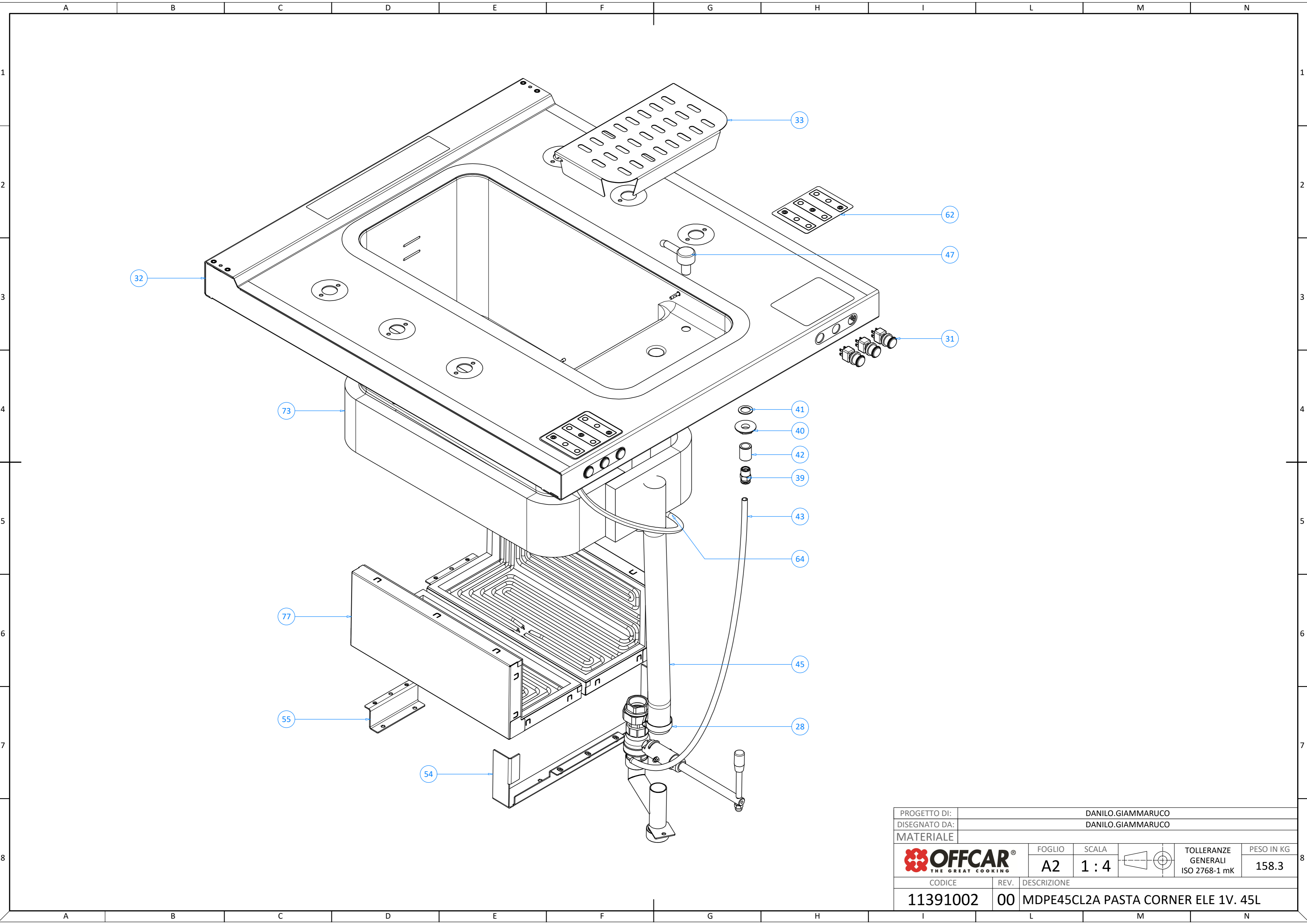

PROGETTO DI:	DANILO.GIAMMARUCO			
DISEGNATO DA:	DANILO.GIAMMARUCO			
MATERIALE	FOGLIO	SCALA	TOLLERANZE GENERALI	PESO IN KG
	A2	1 : 4	ISO 2768-1 mK	158.3
CODICE	REV.	DESCRIZIONE		
11391002	00	MDPE45CL2A PASTA CORNER ELE 1V. 45L		

A		B		C		D		E		F		G		H		I		L		M		N	
N°	QTÀ	CODICE		REV.	DESCRIZIONE (ITA)	DESCRIPTION (EN)						BESCHREIBUNG (DE)				DESCRIPTION (FR)				DESCRIPCIÓN (ES)			
28	2	830801		00	FASCETTA ABA ALUZINK DIAM.32-44																		
31	6	862326		00	PULSANTE INOX MONOPOLO IP40 10A																		
32	1	20400088		02	ASS. TELAIO ALZ. SUP.80X90 PASTACOR																		
33	1	60200829		00	GRIGLIETTA FORATA CUOC.PIEGATA MILO																		
39	1	80300220		00	RACC RAPIDO MASCHIO 3/8 D. 10																		
40	1	80300471		00	DADO FLANGIATO OTTONE 3/8																		
41	1	80300223		00	GUARNIZIONE EROGATORE CPG MILO																		
42	1	829831		00	MANICOTTO INOX DA 3/8"																		
43	1	60200854		01	TUBO PTFE D.10 EROG. PASTACORNER																		
45	1	60201475		00	TUBO SCARICO CUOCIPASTA D.40X650																		
47	1	20400052		03	SAL. EROGATORE H2O CPG-PASTACORNER																		
54	1	4200515		06	RINFORZO RESIST. CUOC. ELETTRICO																		
55	2	4200514		05	SUPPORTO ANT./POST. RESISTENZE CPE																		
62	2	80300554		00	ETICHETTA CONT ALZAC PASTACORNER S9																		
64	1	60200868		01	TUBO PTFE D.10 CARICO AUTO CPG																		
73	1	80300619		01	COIBENTAZIONE VASCA CPE S9																		
77	2	843860		01	RESISTENZA ANGOL.4500W 400V MORS.UL																		



PROGETTO DI:	DANILO.GIAMMARUCO				
DISEGNATO DA:	DANILO.GIAMMARUCO				
MATERIALE					
	FOGLIO	SCALA		TOLLERANZE GENERALI ISO 2768-1 mK	PESO IN KG
	A2	1 : 8			158.3
CODICE	REV.	DESCRIZIONE			
11391002	00	MDPE45CL2A PASTA CORNER ELE 1V. 45L			

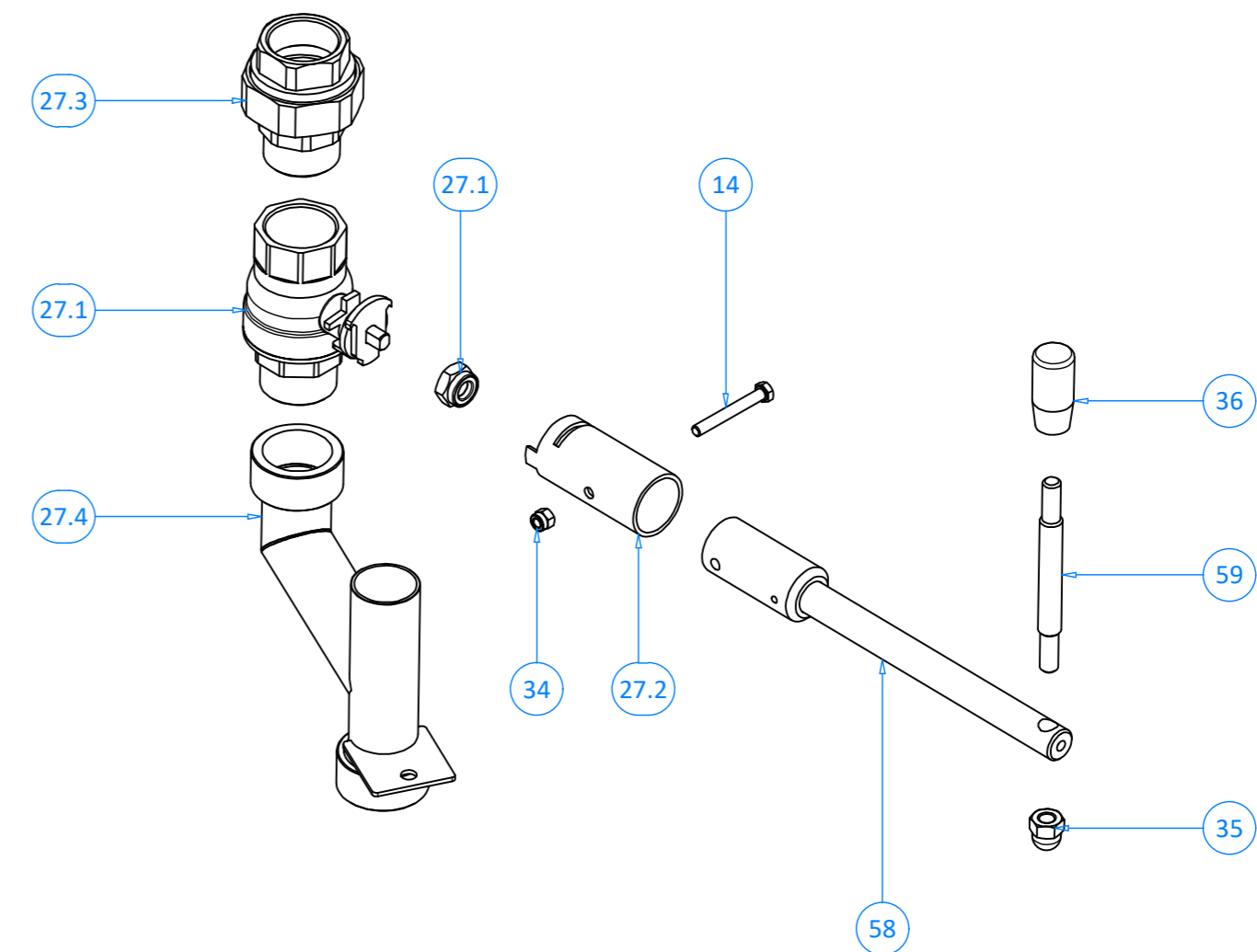
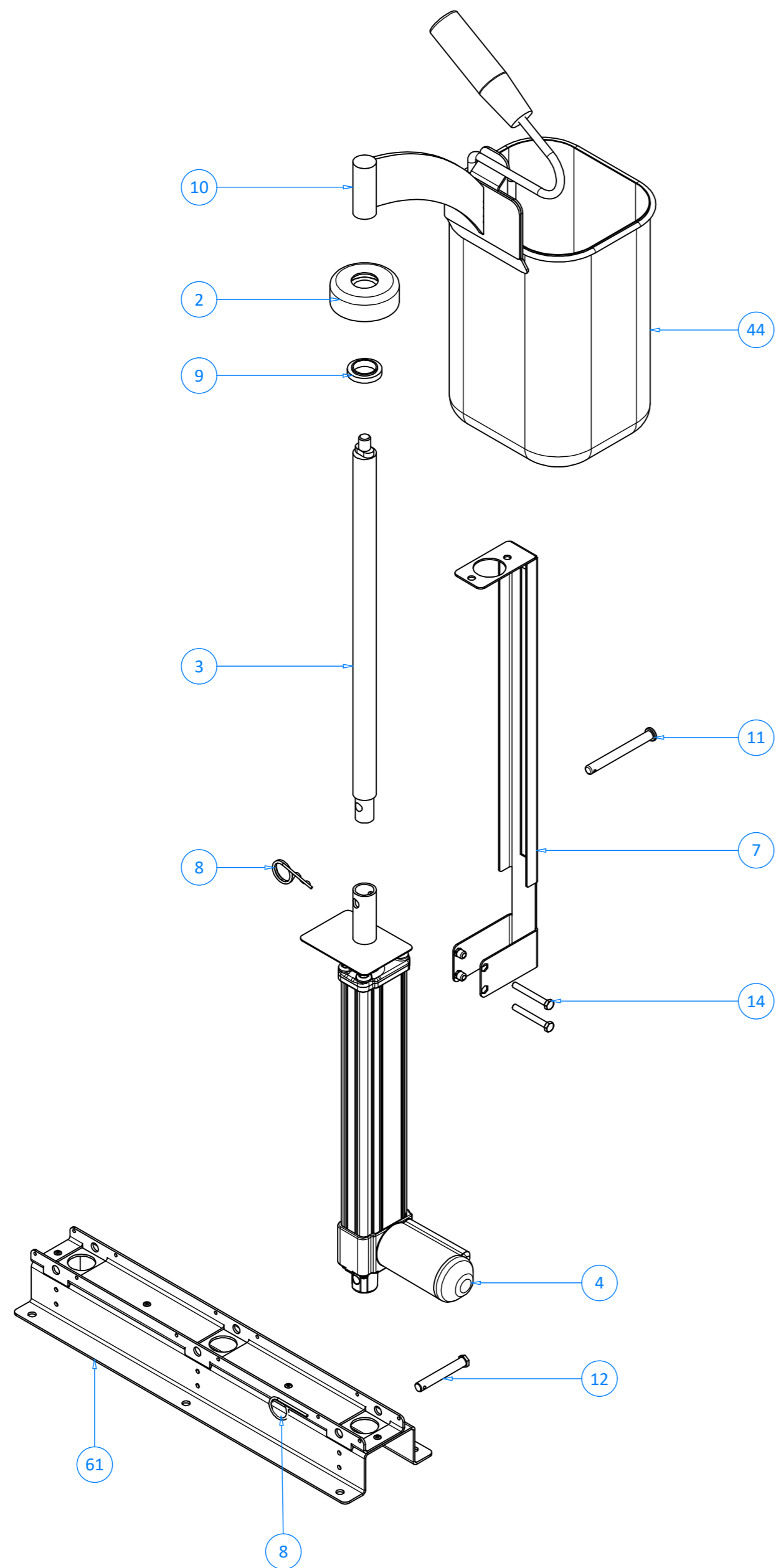

PROGETTO DI:	DANILO.GIAMMARUCO			
DISEGNATO DA:	DANILO.GIAMMARUCO			
MATERIALE	FOGLIO	SCALA	TOLLERANZE GENERALI	PESO IN KG
	A2	1 : 4	ISO 2768-1 mK	158.3
CODICE	REV.	DESCRIZIONE		
11391002	00	MDPE45CL2A PASTA CORNER ELE 1V. 45L		

A		B		C		D		E		F		G		H		I		L		M		N							
ELENCO PARTI																													
N°	QTÀ	CODICE		REV.	DESCRIZIONE (ITA)	DESCRIPTION (EN)						BESCHREIBUNG (DE)						DESCRIPTION (FR)						DESCRIPCIÓN (ES)					
2	6	841310		01	BOCCOLA CENTRAGGIO X BARRE ALZAC.																								
3	6	834005		03	ASTA DI SOLLEVAM. X ALZAC. CUOCIP.																								
4	6	850104		00	ATTUATORE UL CORSA 210MM 6815238																								
7	6	4200365		05	SUPPORTO ANTIROTAZ. X ALZACESTI																								
8	12	851130		00	COPIGLIA INOX "R" 2165F D.2																								
9	6	862085		00	ANELLO RASCHIATORE SAB20 ALZACESTI																								
10	6	4200370		04	SUPP.ALZACESTI.CUOCIP.S.700/980S																								
11	6	852946		00	PERNO DA INNESTO INOX A4 8X74																								
12	6	852944		00	PERNO DA INNESTO INOX A4 8X54																								
14	13	852053		00	VITE TE INOX M5X40 DIN933																								
27.1	1	829522		00	RUBINETTO SFERA INOX 316 M/F 1																								
27.2	1	20200085		00	SAL. ATTACCO PROLUNGA VALV. 1"																								
27.3	1	829790		00	BOCCHETTONE 3 PZ 1" MF INOX 316																								
27.4	1	80300256		03	CONDOTTO GRUPPO SCARICO CPG/PSTCRN																								
34	1	853655		00	DADO INOX M5 AUTOBLOCCANTE																								
35	1	80300053		00	DADO M8 CIECO CON CALOTTA DIN 1587																								
36	1	80300057		00	MANIGLIA ELESA RIF. 21602																								
44	6	861142		00	CESTO CUOCIPASTA NERO GN1/6DX H215																								
58	1	20200087		02	SAL. ASTA PROLUNGA CON BUSSOLA CPG																								
61	2	20100509		00	ASS. OMEGA SUPP. ATTUAT. ALZAC S.90																								

PROGETTO DI:	DANILO.GIAMMARUCO										
DISEGNATO DA:	DANILO.GIAMMARUCO										
MATERIALE											
		FOGLIO	SCALA			TOLLERANZE GENERALI	PESO IN KG				
		A2	1 : 8			ISO 2768-1 mK	158.3				
CODICE	REV.	DESCRIZIONE									
11391002	00	MDPE45CL2A PASTA CORNER ELE 1V. 45L									

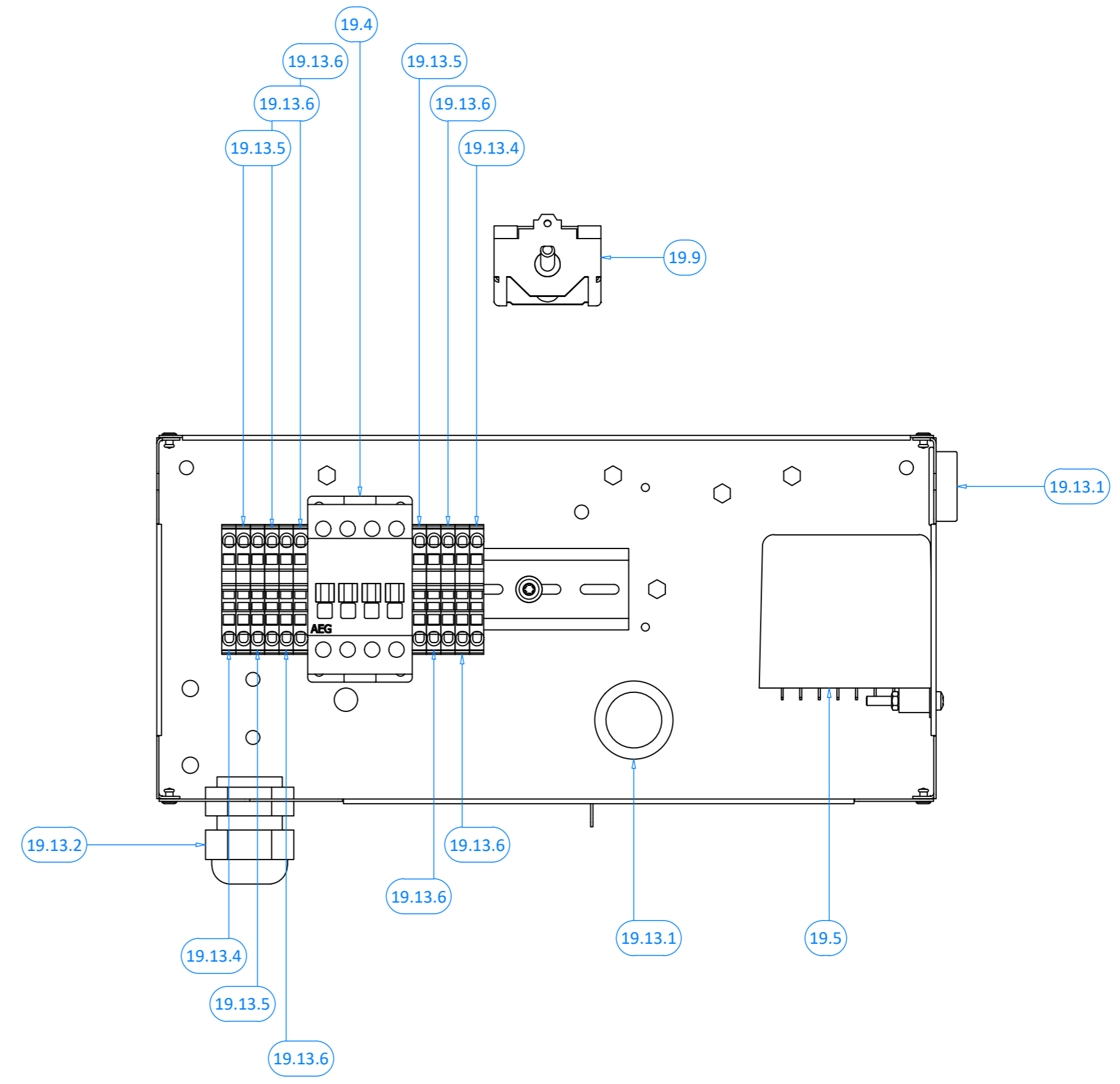
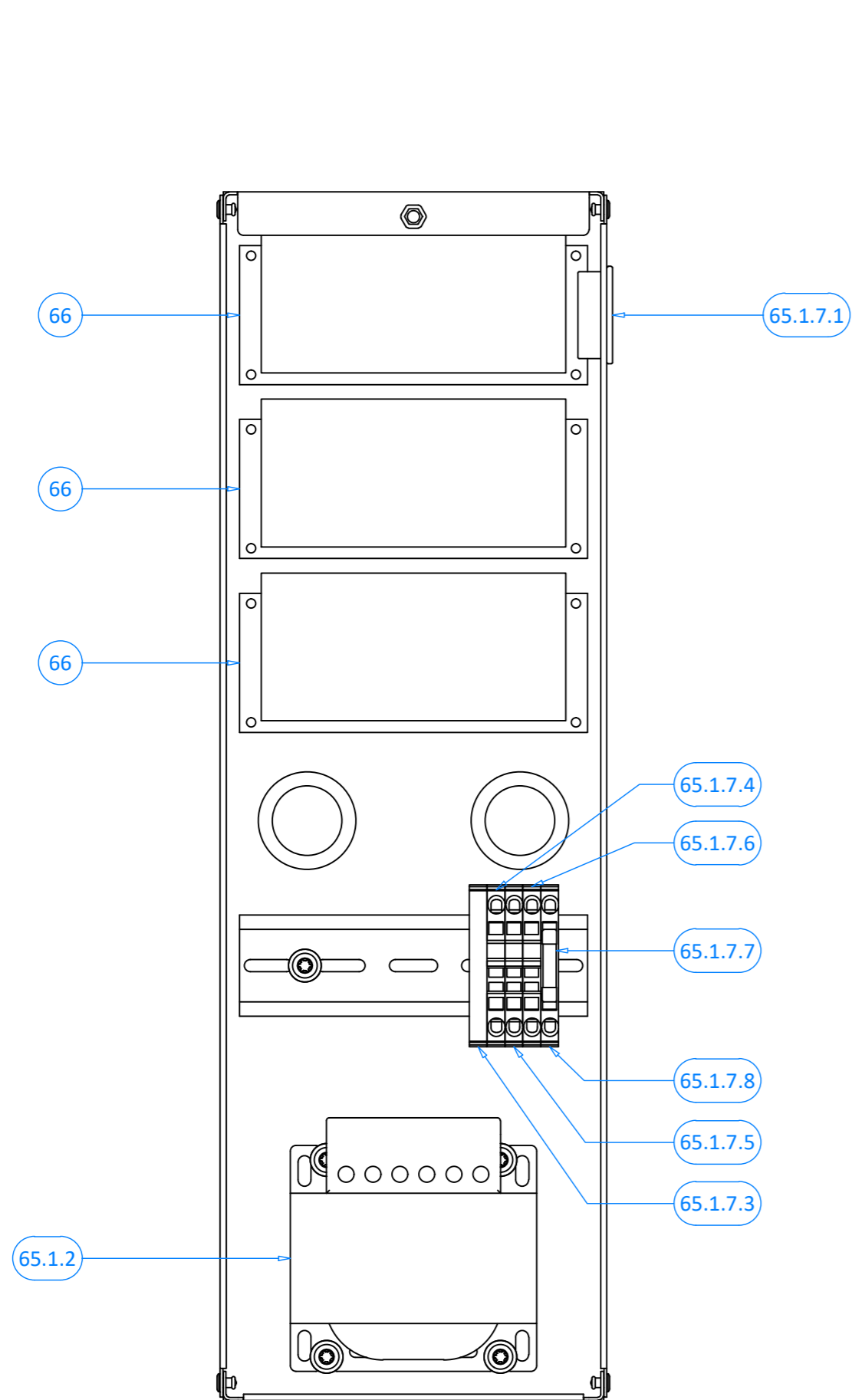

PROGETTO DI:	DANILO.GIAMMARUCO			
DISEGNATO DA:	DANILO.GIAMMARUCO			
MATERIALE	FOGLIO	SCALA	TOLLERANZE GENERALI	PESO IN KG
OFFCAR THE GREAT COOKING	A2	1 : 2	ISO 2768-1 mK	158.3
CODICE	REV.	DESCRIZIONE		
11391002	00	MDPE45CL2A PASTA CORNER ELE 1V. 45L		

A		B		C		D		E		F		G		H		I		L		M		N							
ELENCO PARTI																													
N°	QTÀ	CODICE		REV.	DESCRIZIONE (ITA)	DESCRIPTION (EN)						BESCHREIBUNG (DE)						DESCRIPTION (FR)						DESCRIPCIÓN (ES)					
19.4	1	835942		00	TELER/CONTATT.QUADRI. 25A AC1 230V																								
19.5	1	80300154		00	REGOLATORE DI LIVELLO RL30																								
19.9	1	843747		00	COMMUTATORE 0-3 POSIZIONI.16 AMP.																								
19.10	1	80300377		00	MLV SEG.LUM.LED ROSSO 12V																								
19.11	1	80300211		00	MLV SEG.LUM.LED VERDE 400V																								
19.12	1	80300212		00	MLV SEG.LUM. LED ARANCIO 400V																								
19.13.1	2	819136		00	BOCCOLA PASSAGGIO CAVI LEGNB																								
19.13.2	1	849511		00	PRESSACAVO+DADO CEMBRE PG21																								
19.13.4	2	80300510		00	MORSETTO TERRA PHOENIX CONTACT 32A																								
19.13.5	3	80300511		00	MORSETTO NEUTRO PHOENIX CONTACT 32A																								
19.13.6	6	80300509		00	MORSETTO FASE PHOENIX CONTACT 32A																								
19.13.7	1	849031		00	CAVO ALIMENT. 5X2,5X3,5MT H07RN-F																								
19.13.8	1	80300472		00	CABLAGGIO CUOCIPASTA ELE																								
65.1.2	2	992832		00	TRASFORM. 100VA 24V BOTTBTMS01024																								
65.1.7.1	6	819136		00	BOCCOLA PASSAGGIO CAVI LEGNB																								
65.1.7.3	2	80300513		00	BLOCCHETTO TERM. PHOENIX CONTACT																								
65.1.7.4	2	80300511		00	MORSETTO NEUTRO PHOENIX CONTACT 32A																								
65.1.7.5	2	80300509		00	MORSETTO FASE PHOENIX CONTACT 32A																								
65.1.7.6	2	80300510		00	MORSETTO TERRA PHOENIX CONTACT 32A																								
65.1.7.7	2	819126		00	FUSIBILE 5X20 1,25A RIT. ITW01																								
65.1.7.8	2	80300512		00	MORSETTO SEZION. PHOENIX CONTACT																								
65.1.7.9	2	80300650		00	CABLAGGIO COMPLETO MDPE MILO																								
66	6	856001		00	SCHEDA POTENZA F1 24VAC CON CONNETT																								



PROGETTO DI:	DANILO.GIAMMARUCO				
DISEGNATO DA:	DANILO.GIAMMARUCO				
MATERIALE					
	FOGLIO	SCALA		TOLLERANZE GENERALI	PESO IN KG
	A2	1 : 8		ISO 2768-1 mK	158.3
CODICE	REV.	DESCRIZIONE			
11391002	00	MDPE45CL2A PASTA CORNER ELE 1V. 45L			

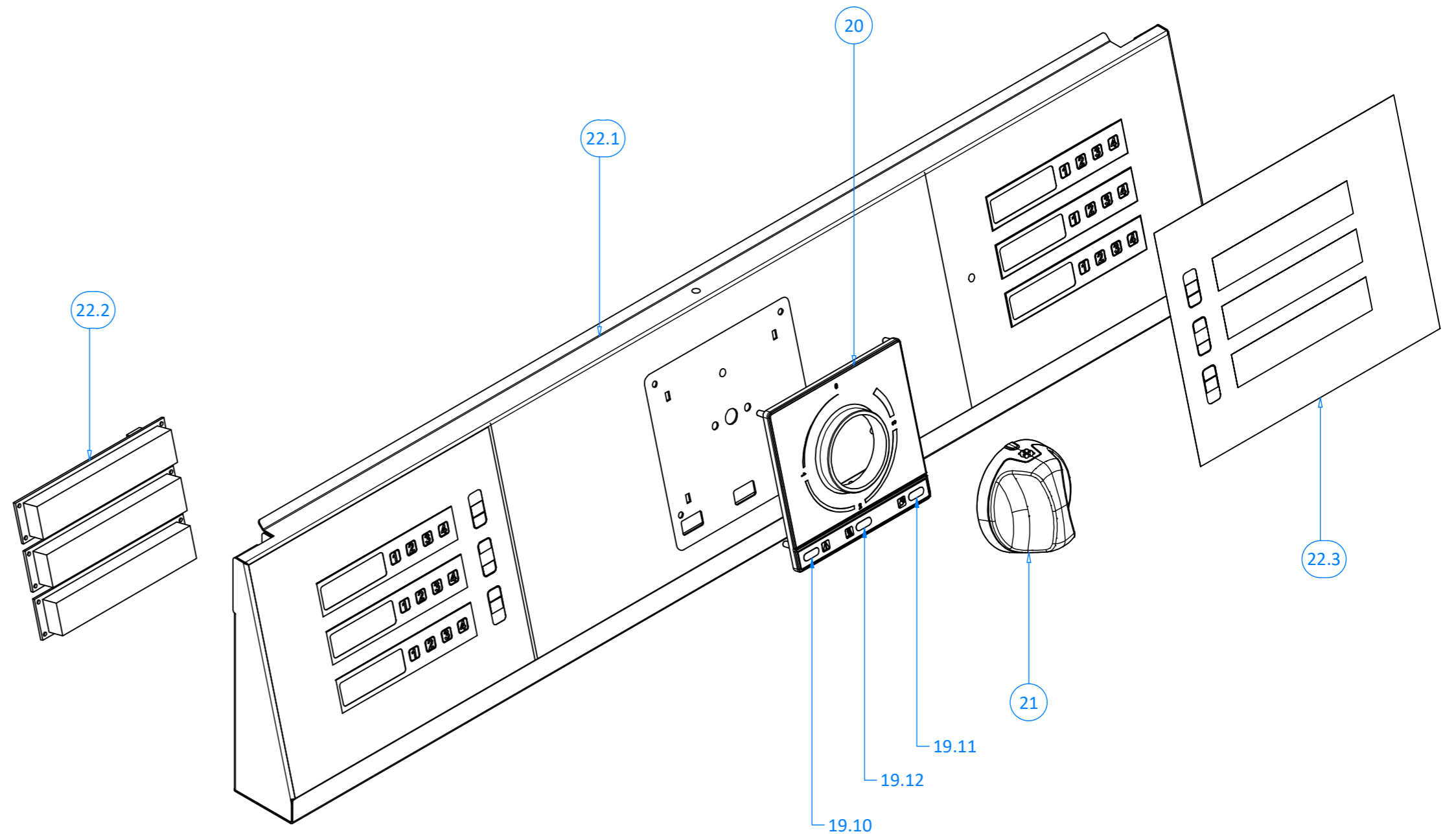
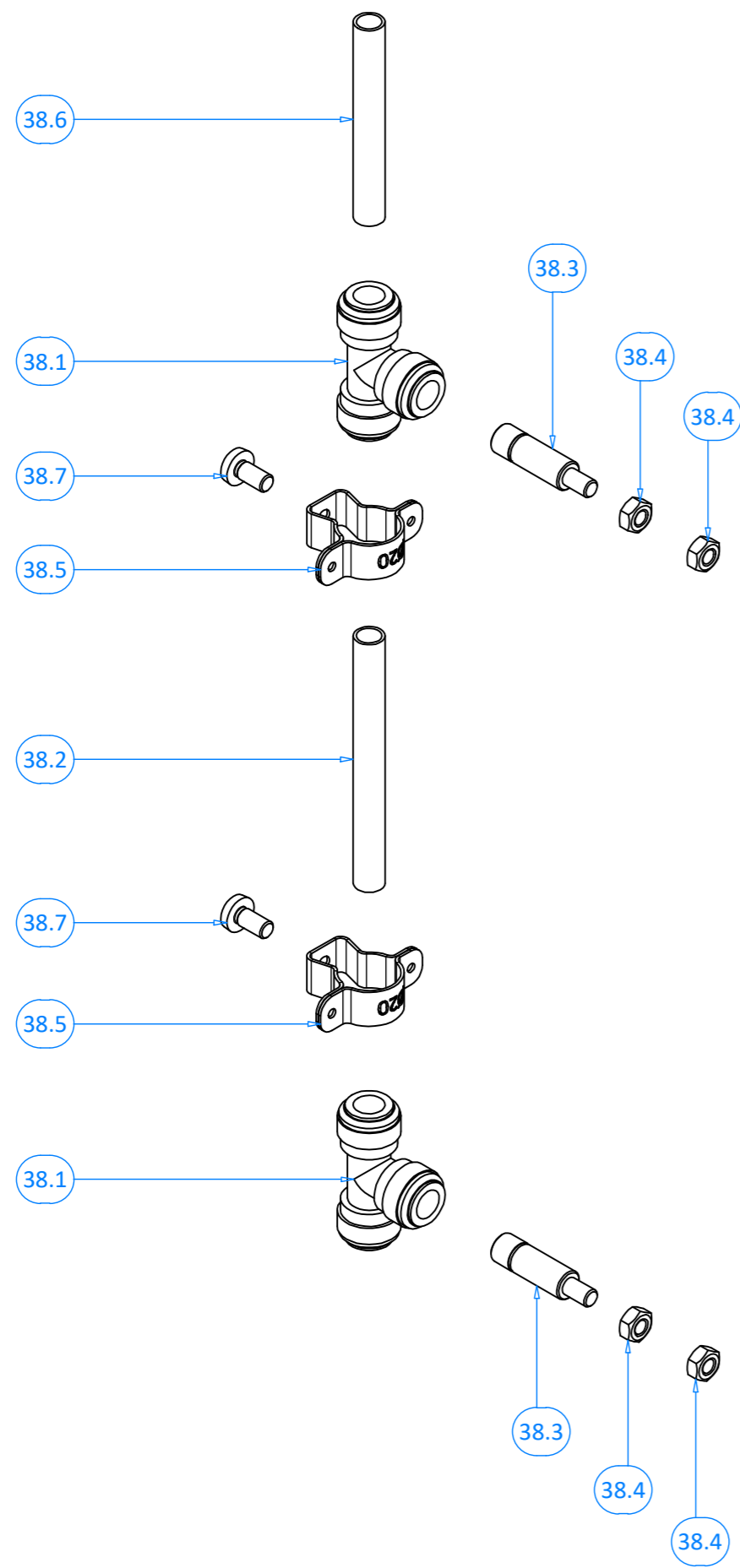

PROGETTO DI:	DANILO.GIAMMARUCO			
DISEGNATO DA:	DANILO.GIAMMARUCO			
MATERIALE	FOGLIO	SCALA	TOLLERANZE GENERALI	PESO IN KG
	A2	1 : 3	ISO 2768-1 mK	158.3
CODICE	REV.	DESCRIZIONE		
11391002	00	MDPE45CL2A PASTA CORNER ELE 1V. 45L		

A		B		C		D		E		F		G		H		I		L		M		N	
N°	QTÀ	CODICE		REV.	DESCRIZIONE (ITA)	DESCRIPTION (EN)		BESCHREIBUNG (DE)		DESCRIPTION (FR)		DESCRIPCIÓN (ES)											
20	1	80300128		00	GHIERA CUOCIPASTA MILO ELE																		
21	1	80300100		01	MANOPOLA MILO D.6 ELE																		
22.1	1	20100069		02	ASS. CRUSCOTTO PASTACORNER																		
22.2	6	20100643		00	ASS. SCHEDA TOUCH CON ETICH 1-2-3-4																		
22.3	2	80300210		00	TARGA AD.CRUSC.ALZACESTI NERA MILO																		
38.1	2	992568		00	"RACCORDO INTERMEDIO ""T"" HUT1010W"																		
38.2	1	60201741		00	TUBO PTFE LIVELLO CARICO AUTOM Ø10																		
38.3	2	60200657		01	PERNO SENSORE LIVELLO																		
38.4	4	853671		00	DADO INOX M6 DIN 934																		
38.5	2	830816		00	COLLARE METALLICO FORO M6 TAZ20																		
38.6	1	60201424		03	TUBO PTFE D.10 SFIATO AUTO CPG																		
38.7	2	852295		00	VITE INOX POALIERS M6X12																		

ELENCO PARTI

PROGETTO DI:	DANILO.GIAMMARUCO				
DISEGNATO DA:	DANILO.GIAMMARUCO				
MATERIALE					
	FOGLIO	SCALA		TOLLERANZE GENERALI	PESO IN KG
	A2	1 : 8		ISO 2768-1 mK	158.3
CODICE	REV.	DESCRIZIONE			
11391002	00	MDPE45CL2A PASTA CORNER ELE 1V. 45L			