

SEZIONE A - A

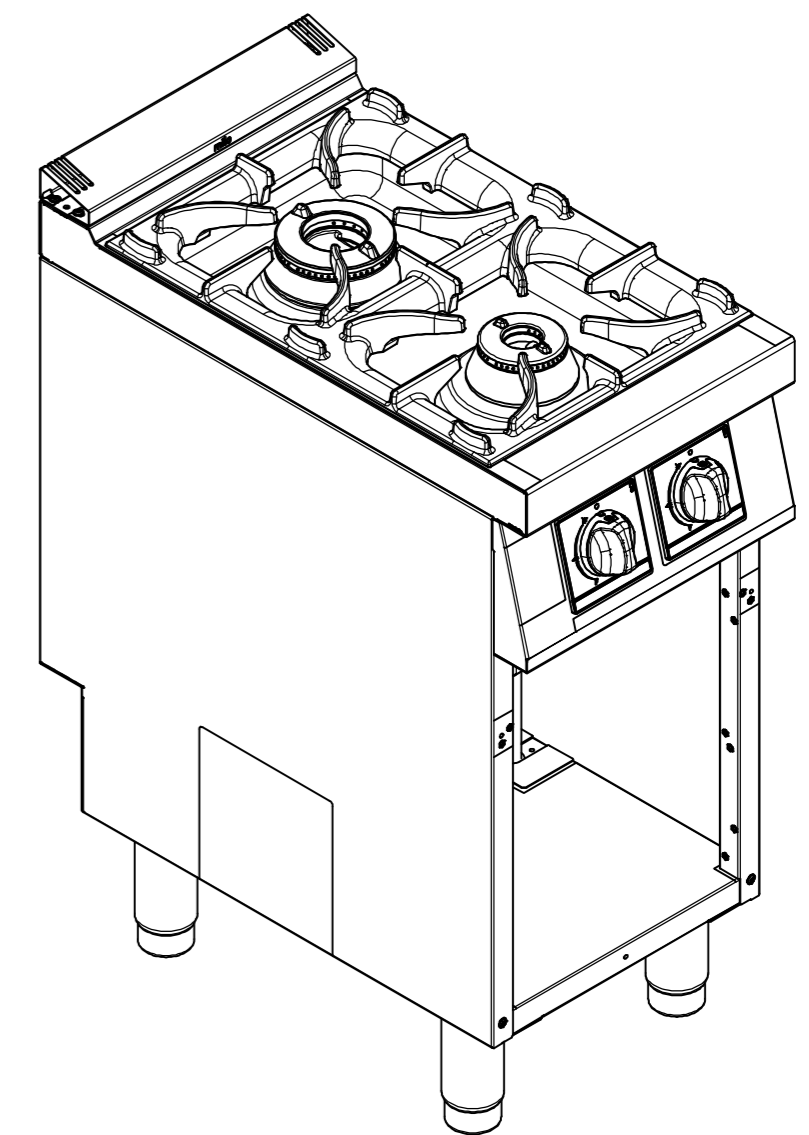

REV.	DESCRIZIONE	APPROVATO DA	DATA
00	Emesso	VLADUT.IACOMI	12/03/2025
PROGETTO DI: VLADUT.IACOMI DISEGNATO DA: DANILO.GIAMMARUCO			
MATERIALE			
		FOGLIO A2	SCALA 1 : 8
			TOLLERANZE GENERALI ISO 2768-1 mK
		PESO IN KG 41.67	
CODICE	REV.	DESCRIZIONE	
10172006	00	M7CBG02 CUCINA GAS 2 FUOCHI 400X700	

A		B		C		D		E		F		G		H		I		L		M		N							
ELENCO PARTI																													
N°	QTÀ	CODICE		REV.	DESCRIZIONE (ITA)	DESCRIPTION (EN)						BESCHREIBUNG (DE)						DESCRIPTION (FR)						DESCRIPCIÓN (ES)					
1	1	20100054		02	ASS. PREAS. MANTELLO S70 - 400 PUL.																								
2	23	80300258		00	INSERTO M5 ESAGONO ZINCATO																								
3	1	60201061		04	TRAVERSA RINFORZO MOBILE 400 MILO																								
4	3	80300260		00	VITE AUTOFIL. DIN 7981/TX 4,8X13 ZNC																								
5	1	80300138		00	LOGO OFFCAR 36X36 METAL THIN LABEL																								
6	1	60201651		00	TAPPO RAMPA BASAMENTO MILO																								
7	1	20100561		00	ASS. CRUSCOTTO CUCINA 2F MILO MG																								
8	2	80300098		02	MANOPOLA MILO GAS D.8																								
9	1	80300125		00	GHIERA MACCHINE MILO GAS POSTERIORE																								
10	1	80300124		00	GHIERA MACCHINE MILO GAS ANTERIORE																								
11	31	80300259		00	VITE TB TX25 FLANG.A2 INOX M5X12																								
12	1	60201667		01	PROT. CUCINA 400 S700 MILO																								
13	1	440109		00	GRIGLIA VET.2F. S.70 575X395 GV-700																								
14	1	60200928		04	COPERTURA FORO PIANO MILO - 400																								
15	1	20200106		07	SAL. TELAIO 40X70 VTC/IND/CUC MILO																								
16	1	20300003		01	IMBALLO 400 MILO																								
17	2	60201668		01	OMEGA SUPPORTO BRUC. 2F CBG - S7																								
18	1	20100660		00	ASS. GRUPPO GAS MILO 7,5 KW																								
19	1	20300018		00	BAC. SOTTOS. S7 FORATA DC - SBAV.																								
20	1	20100584		00	ASS. GRUPPO GAS MILO 4.5 KW																								
21	1	837233		00	TERMOCOPPIA QUICK DA 320 0290012																								
22	1	837243		00	TERMOCOPPIA QUICK DA 600 0290016																								
23	1	817361		02	TUBO GAS 10 BRUC.ANT. L. S.700S																								
24	1	817371		02	TUBO GAS 10 BRUC.POST.L.70S-EVO 700																								
25	1	817341		02	TUBO GAS 6 PIL.POST. S.700S																								
26	1	8173011		05	TUBO GAS 6 PIL. ANT. S.70/S.90 EVO																								
27	1	20100628		00	ASS. PREASS. DISTRIB. CBG 2F MILO																								
28	1	20300024		00	KIT GIUNZIONE MACCHINE																								

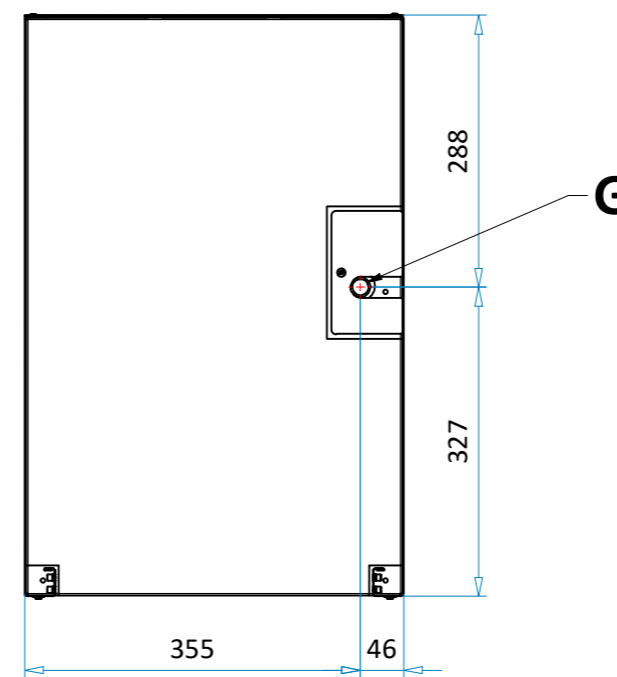

PROGETTO DI:	VLADUT.IACOMI				
DISEGNATO DA:	DANILO.GIAMMARUCO				
MATERIALE					
	FOGLIO	SCALA		TOLLERANZE GENERALI	PESO IN KG
	A2	1 : 8		ISO 2768-1 mK	41.67
CODICE	REV.	DESCRIZIONE			
10172006	00	M7CBG02 CUCINA GAS 2 FUOCHI 400X700			

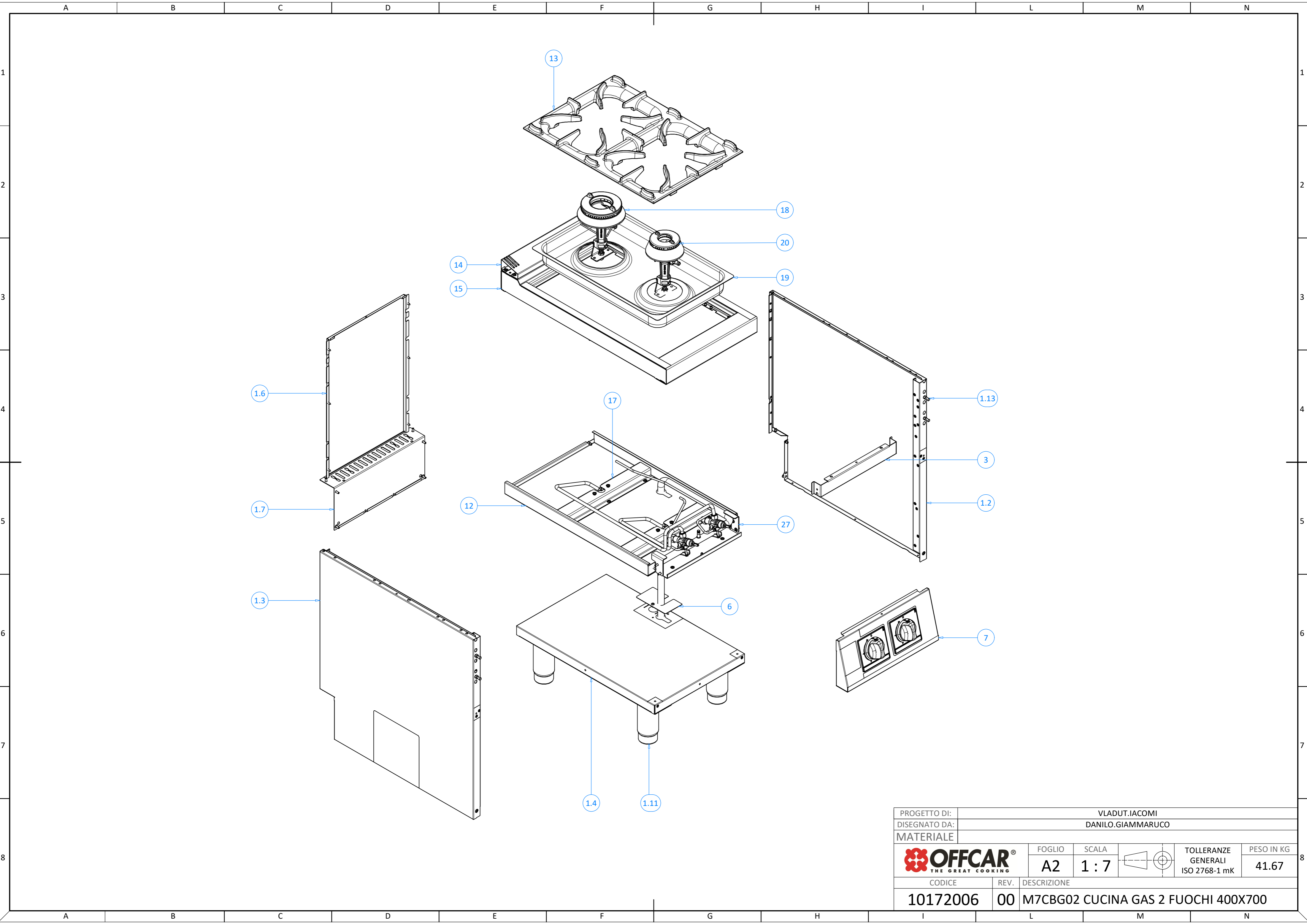

PROGETTO DI:		VLADUT.IACOMI			
DISEGNATO DA:		DANILO.GIAMMARUCO			
MATERIALE					
	FOGLIO	SCALA		TOLLERANZE GENERALI ISO 2768-1 mK	PESO IN KG 41.67
	A2	1 : 7			
CODICE	REV.	DESCRIZIONE			
10172006	00	M7CBG02 CUCINA GAS 2 FUOCHI 400X700			

A		B		C		D		E		F		G		H		I		L		M		N	
N°	QTÀ	CODICE		REV.	DESCRIZIONE (ITA)	DESCRIPTION (EN)		BESCHREIBUNG (DE)		DESCRIPTION (FR)		DESCRIPCIÓN (ES)											
1.2	1	60200049		15	FIANCO DX SERIE 70 - MILO																		
1.3	1	60200050		15	FIANCO SX SERIE 70 - MILO																		
1.4	1	60200472		06	BASAMENTO S.70 400 INOX PULITO																		
1.6	1	60200462		10	SCHIENA RINFORZATA 400 MILO																		
1.7	1	60200672		05	ANGOL. CHIUSURA POST. FOR. 400 MILO																		
1.11	4	80300255		00	PIEDE 2" INOX 150 - 210																		
1.13	4	829541		00	MANIGLIETTE FE/ZN 9X34XM5 CRUS																		
3	1	60201061		04	TRAVERSA RINFORZO MOBILE 400 MILO																		
6	1	60201651		00	TAPPO RAMPA BASAMENTO MILO																		
7	1	20100561		00	ASS. CRUSCOTTO CUCINA 2F MILO MG																		
12	1	60201667		01	PROT. CUCINA 400 S700 MILO																		
13	1	440109		00	GRIGLIA VET.2F. S.70 575X395 GV-700																		
14	1	60200928		04	COPERTURA FORO PIANO MILO - 400																		
15	1	20200106		07	SAL. TELAIO 40X70 VTC/IND/CUC MILO																		
17	2	60201668		01	OMEGA SUPPORTO BRUC. 2F CBG - S7																		
18	1	20100660		00	ASS. GRUPPO GAS MILO 7,5 KW																		
19	1	20300018		00	BAC. SOTTOS. S7 FORATA DC - SBAV.																		
20	1	20100584		00	ASS. GRUPPO GAS MILO 4.5 KW																		
27	1	20100628		00	ASS. PREASS. DISTRIB. CBG 2F MILO																		

PROGETTO DI:	VLADUT.IACOMI				
DISEGNATO DA:	DANILO.GIAMMARUCO				
MATERIALE					
	FOGLIO	SCALA		TOLLERANZE GENERALI ISO 2768-1 mK	PESO IN KG
	A2	1 : 8			41.67
CODICE	REV.	DESCRIZIONE			
10172006	00	M7CBG02 CUCINA GAS 2 FUOCHI 400X700			

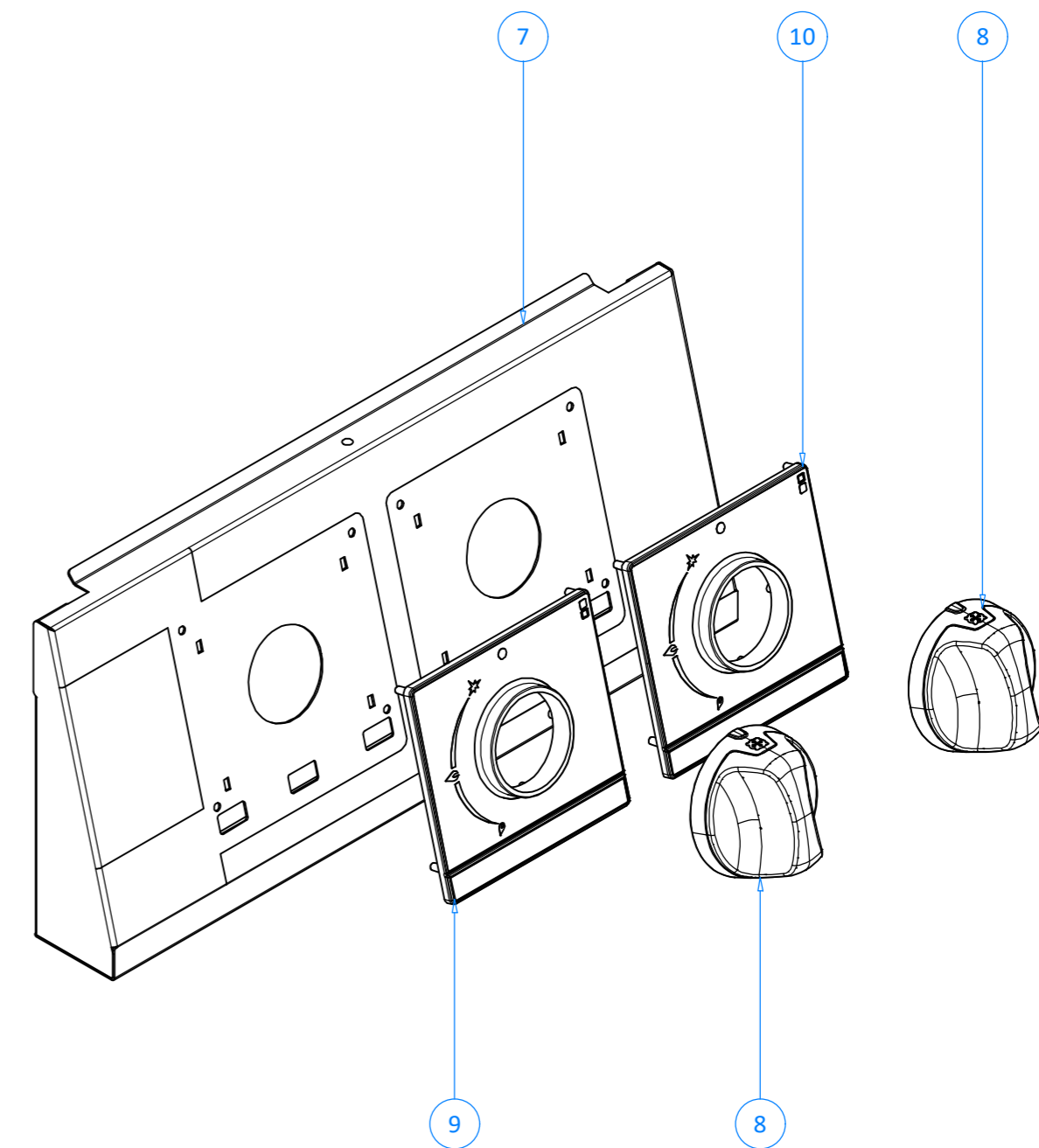
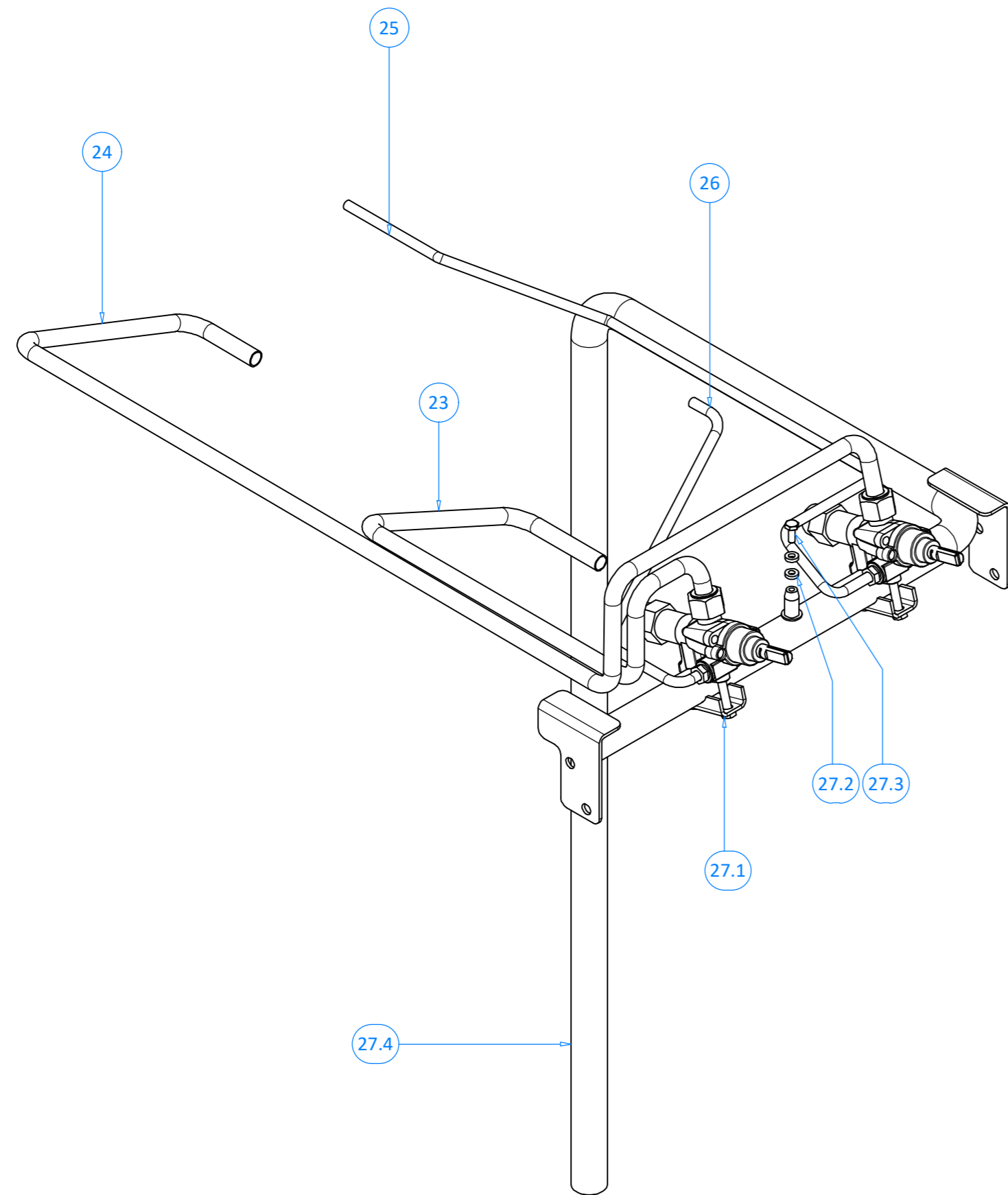

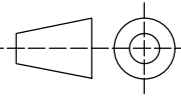
PROGETTO DI:	VLADUT.IACOMI				
DISEGNATO DA:	DANILO.GIAMMARUCO				
MATERIALE					
 OFFCAR <small>THE GREAT COOKING</small>	FOGLIO	SCALA		TOLLERANZE GENERALI	PESO IN KG
	A2	1 : 3		ISO 2768-1 mK	41.67
CODICE	REV.	DESCRIZIONE			
10172006	00	M7CBG02 CUCINA GAS 2 FUOCHI 400X700			

A		B		C		D		E		F		G		H		I		L		M		N	
N°	QTÀ	CODICE		REV.	DESCRIZIONE (ITA)	DESCRIPTION (EN)		BESCHREIBUNG (DE)		DESCRIPTION (FR)		DESCRIPCIÓN (ES)											
7	1	20100561		00	ASS. CRUSCOTTO CUCINA 2F MILO MG																		
8	2	80300098		02	MANOPOLA MILO GAS D.8																		
9	1	80300125		00	GHIERA MACCHINE MILO GAS POSTERIORE																		
10	1	80300124		00	GHIERA MACCHINE MILO GAS ANTERIORE																		
19	1	20300018		00	BAC. SOTTOS. S7 FORATA DC - SBAV.																		
20	1	20100584		00	ASS. GRUPPO GAS MILO 4.5 KW																		
23	1	817361		02	TUBO GAS 10 BRUC.ANT. L. S.700S																		
24	1	817371		02	TUBO GAS 10 BRUC.POST.L.70S-EVO 700																		
25	1	817341		02	TUBO GAS 6 PIL.POST. S.700S																		
26	1	8173011		05	TUBO GAS 6 PIL. ANT. S.70/S.90 EVO																		
27.1	2	401121		00	RUBIN.GAS COLL.COMP.RACC.21S S7/9S																		
27.2	2	853994		00	RONDELLA RAME 4X8X2																		
27.3	1	852491		00	VITE TE INOX FINTA ROND. M4X10																		
27.4	1	80300625		02	DISTRIBUTORE CUCINA 400 MILO V1																		
28	1	20300024		00	KIT GIUNZIONE MACCHINE																		

ELENCO PARTI

PROGETTO DI:	VLADUT.IACOMI				
DISEGNATO DA:	DANILO.GIAMMARUCO				
MATERIALE					
	FOGLIO	SCALA		TOLLERANZE GENERALI ISO 2768-1 mK	PESO IN KG
	A2	1 : 8			41.67
CODICE	REV.	DESCRIZIONE			
10172006	00	M7CBG02 CUCINA GAS 2 FUOCHI 400X700			

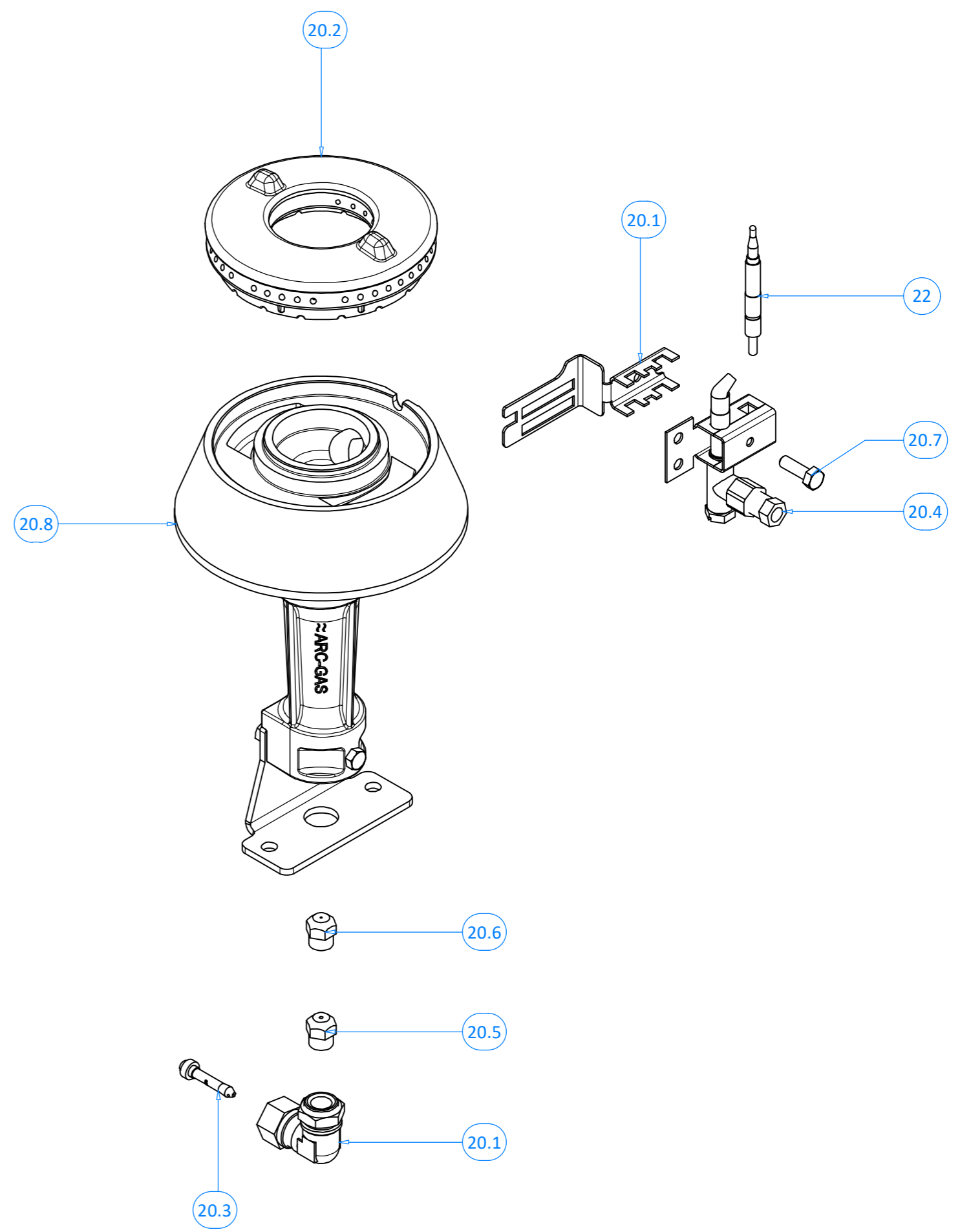
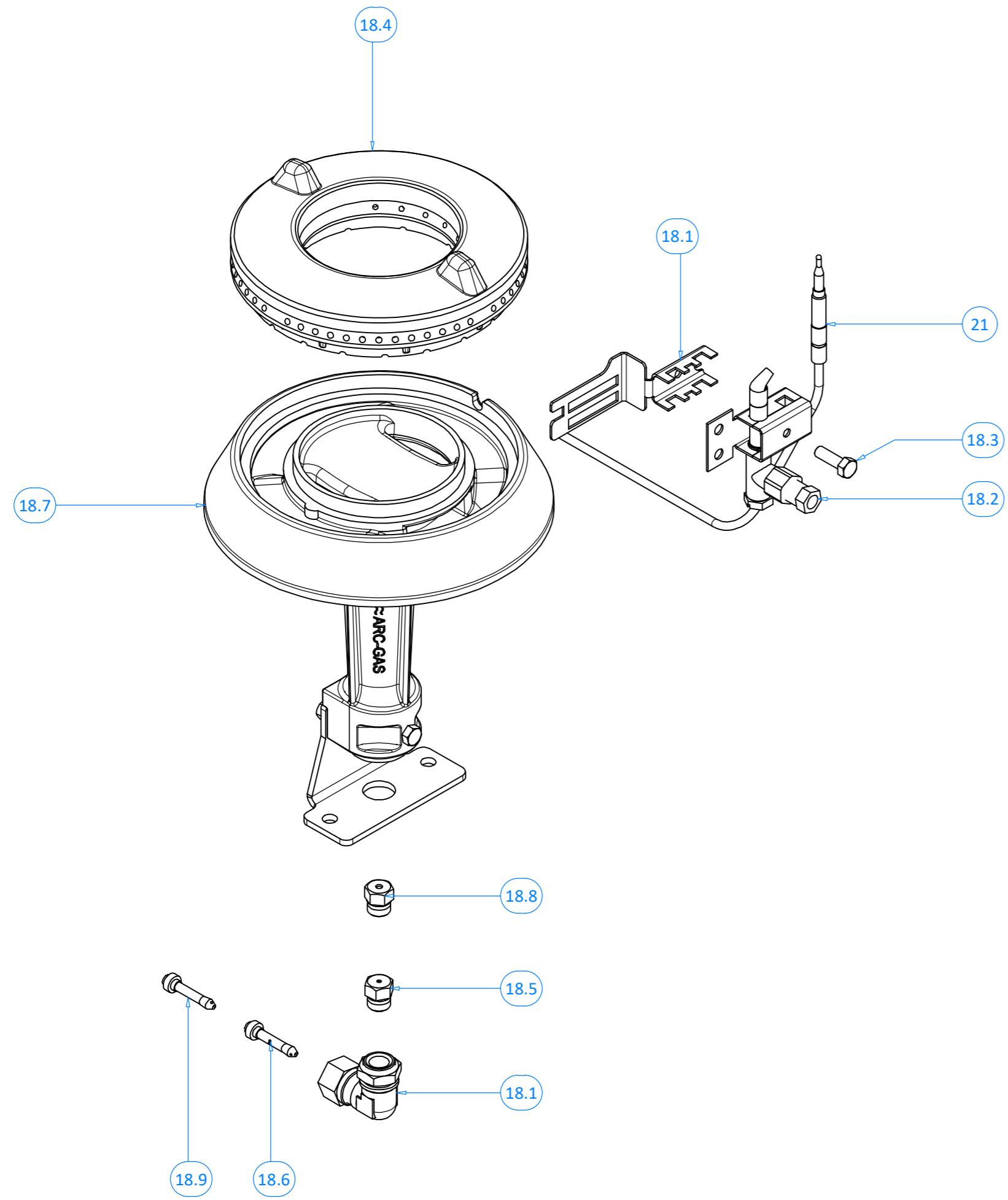

PROGETTO DI:		VLADUT.IACOMI			
DISEGNATO DA:		DANILO.GIAMMARUCO			
MATERIALE		FOGLIO	SCALA	TOLLERANZE GENERALI	PESO IN KG
		A2	1 : 2	ISO 2768-1 mK	41.67
CODICE	REV.	DESCRIZIONE			
10172006	00	M7CBG02 CUCINA GAS 2 FUOCHI 400X700			

A		B		C		D		E		F		G		H		I		L		M		N		
ELENCO PARTI																								
N°	QTÀ	CODICE		REV.	DESCRIZIONE (ITA)				DESCRIPTION (EN)				BESCHREIBUNG (DE)				DESCRIPTION (FR)				DESCRIPCIÓN (ES)			
18.1	1	20100602		01	ASS. SUPP. VENTURI ALL. 10KW																			
18.2	1	837201		00	PILOTA 1 VIA MULTIGAS 0100013																			
18.3	1	852045		00	VITE TE INOX M5*16 DIN933																			
18.4	1	828139		00	SPARTIFIAMMA OT.DOPPIA C.128																			
18.5	1	829323		00	UGELLO M10X1 DIAM 1,30 65.J130																			
18.6	1	837281		00	UGELLO GAS MET.DIAM.0,35 * 0977031																			
18.7	1	827359		00	CORPO BRUC.RE VETRI.DOP.C. 128																			
18.8	1	829322		00	UGELLO ESAG.11 M10X1 Ø0,205 65.J205																			
18.9	1	837297		00	UGELLO GAS GPL DIAM.0,20 * 0977030																			
20.1	1	20100585		01	ASS. SUPP. VENTURI ALL. 4.5KW																			
20.2	1	80300358		00	SPARTIFIAMMA OT.DOPPIA C.96 MILO																			
20.3	1	837281		00	UGELLO GAS MET.DIAM.0,35 * 0977031																			
20.4	1	837201		00	PILOTA 1 VIA MULTIGAS 0100013																			
20.5	1	829333		00	UGELLO OTT.CH11X13 M10X1 F.1,55*155																			
20.6	1	829315		00	UGELLO OTT.CH11X13 M10X1 F.0,95*95																			
20.7	1	852045		00	VITE TE INOX M5*16 DIN933																			
20.8	1	80300357		00	CORPO BRUC.RE VETRI.DOP.C. 96 MILO																			
21	1	837233		00	TERMOCOPPIA QUICK DA 320 0290012																			
22	1	837243		00	TERMOCOPPIA QUICK DA 600 0290016																			

PROGETTO DI:	VLADUT.IACOMI										
DISEGNATO DA:	DANILO.GIAMMARUCO										
MATERIALE											
	FOGLIO	SCALA		TOLLERANZE GENERALI	PESO IN KG						
	A2	1 : 8		ISO 2768-1 mK	41.67						
CODICE	REV.	DESCRIZIONE									
10172006	00	M7CBG02 CUCINA GAS 2 FUOCHI 400X700									