

**GAS FRY-TOPS TOP 800mm X 730mm COD.:**  
**10372021 M7TFGLLS**  
**10372022 M7TFGLLC**  
**10372023 M7TFGLRS**  
**10372024 M7TFGLRC**  
**10372027 M7TFGRRS**  
**10372028 M7TFGRRC**

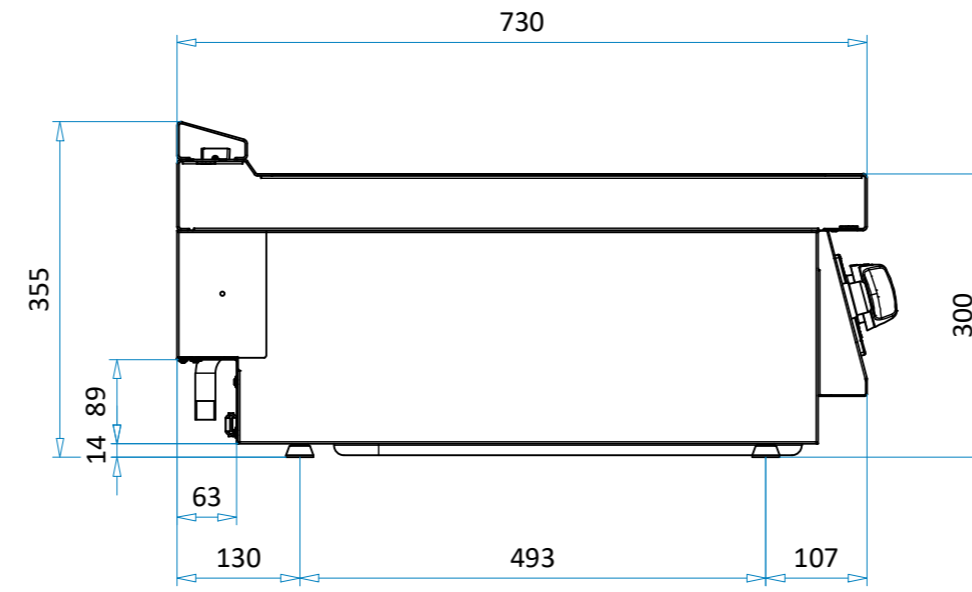

SEZIONE A - A

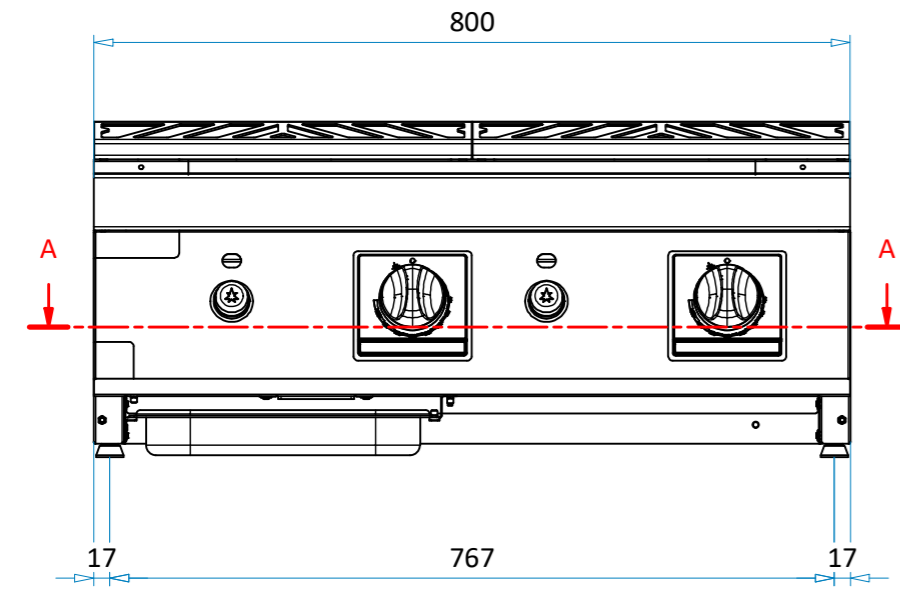
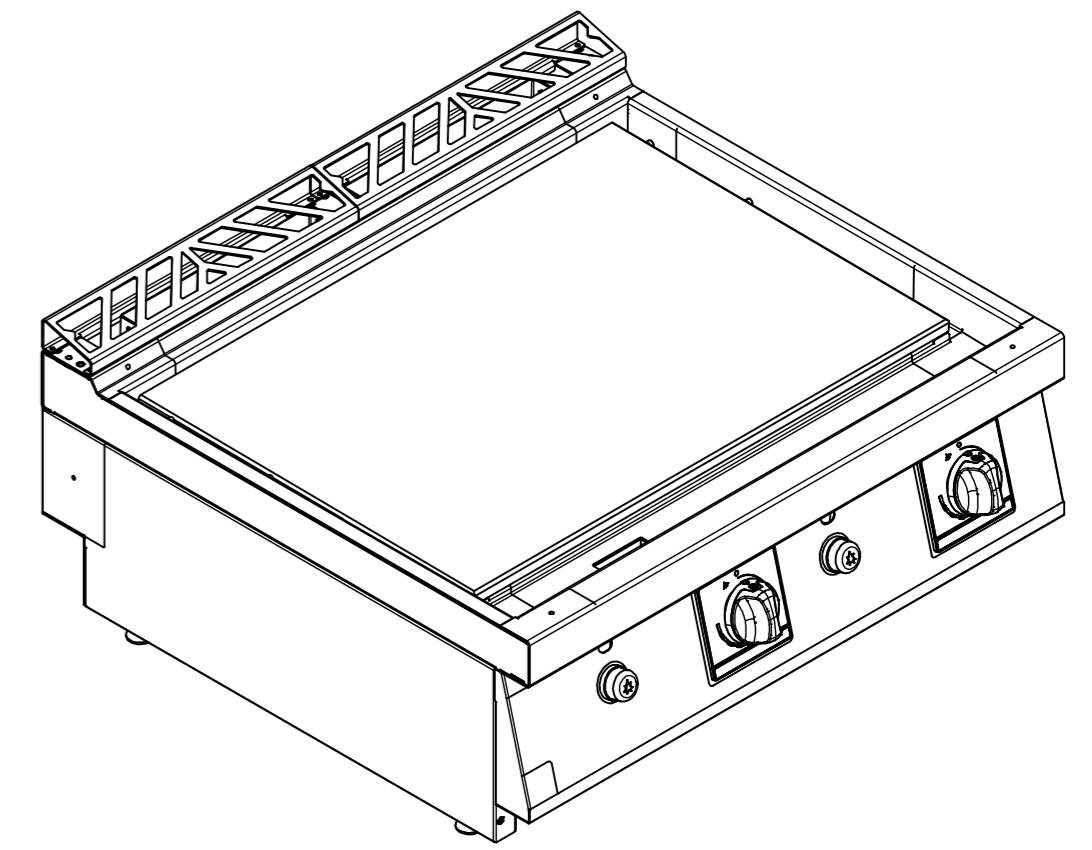
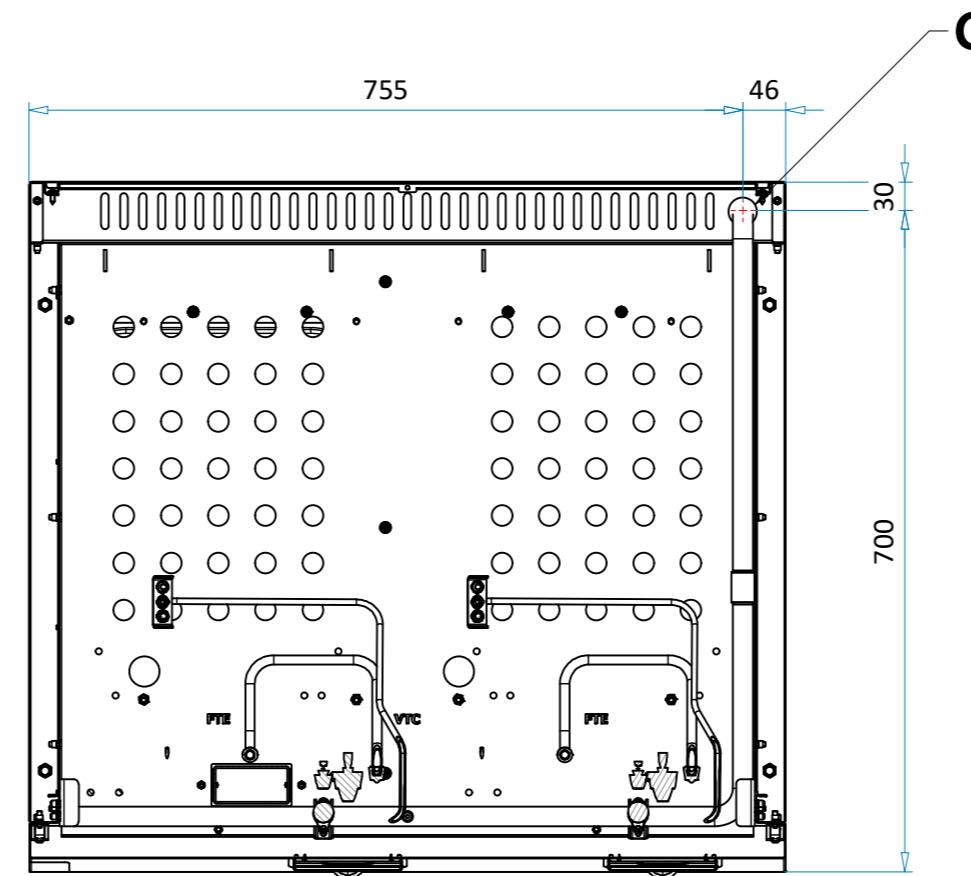
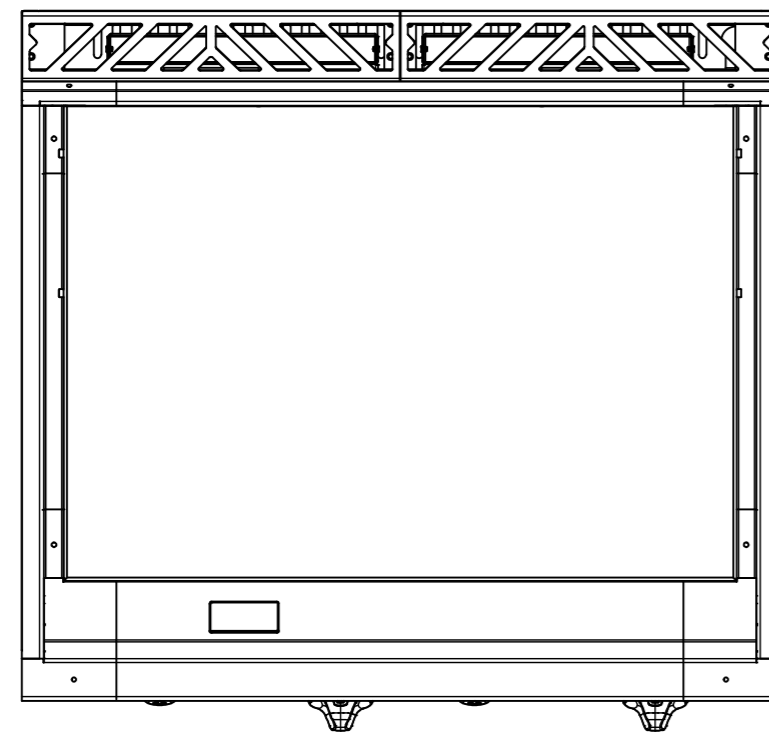

REV.	DESCRIZIONE	APPROVATO DA	DATA
00	Emesso	VLADUT.IACOMI	11/03/2025
PROGETTO DI: <b>DANILO.GIAMMARUCO</b> DISEGNATO DA: <b>DANILO.GIAMMARUCO</b>			
MATERIALE			
		FOGLIO <b>A2</b>	SCALA <b>1 : 8</b>
		TOLLERANZE GENERALI ISO 2768-1 mK	
		PESO IN KG <b>80.73</b>	
CODICE	REV.	DESCRIZIONE	
<b>10372022</b>	<b>00</b>	<b>M7TFGXXX GAS FRY-TOP TOP 800x730</b>	

N°	QTÀ	CODICE	REV.	DESCRIZIONE (ITA)	DESCRIPTION (EN)	BESCHREIBUNG (DE)	DESCRIPTION (FR)	DESCRIPCIÓN (ES)
1	1	20100634	00	ASS. FRYTOP TOP 80X70 GAS MASTER				
2	1	20100286	00	ASS. PIASTRA LC FRYTOP 80X70 MILO				
3	1	20300011	01	IMBALLO 800 MILO TOP				

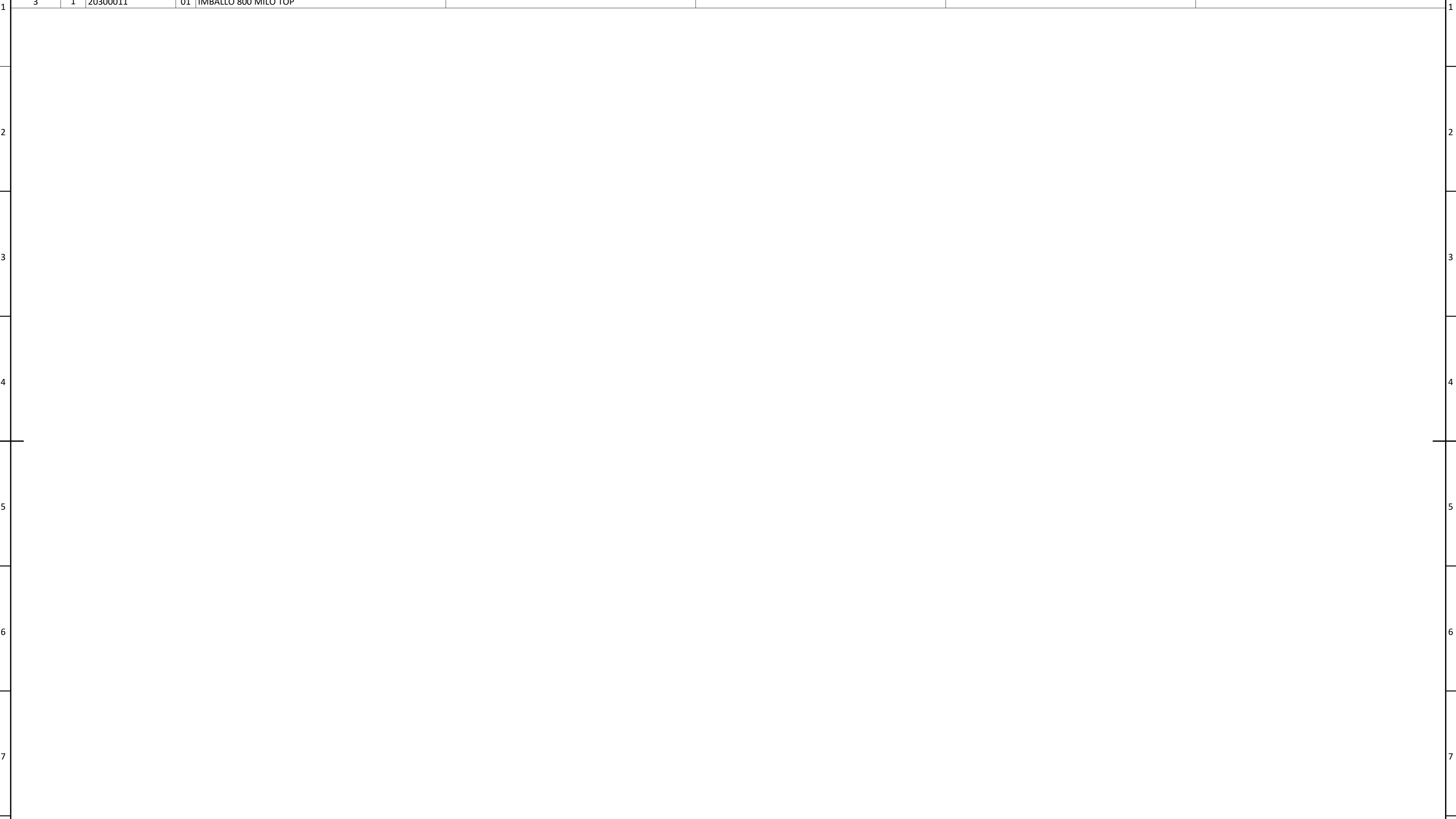

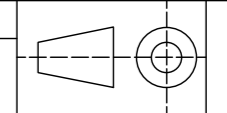
PROGETTO DI:					
DISEGNATO DA:		DANILO.GIAMMARUCO			
MATERIALE					
	FOGLIO	SCALA		TOLLERANZE GENERALI ISO 2768-1 mK	PESO IN KG
	A2				
CODICE	REV.	DESCRIZIONE			
		M7TFGXXX GAS FRY-TOP TOP 800x730			

A B C D E F G H I L M N

1  
2  
3  
4  
5  
6  
7  
8

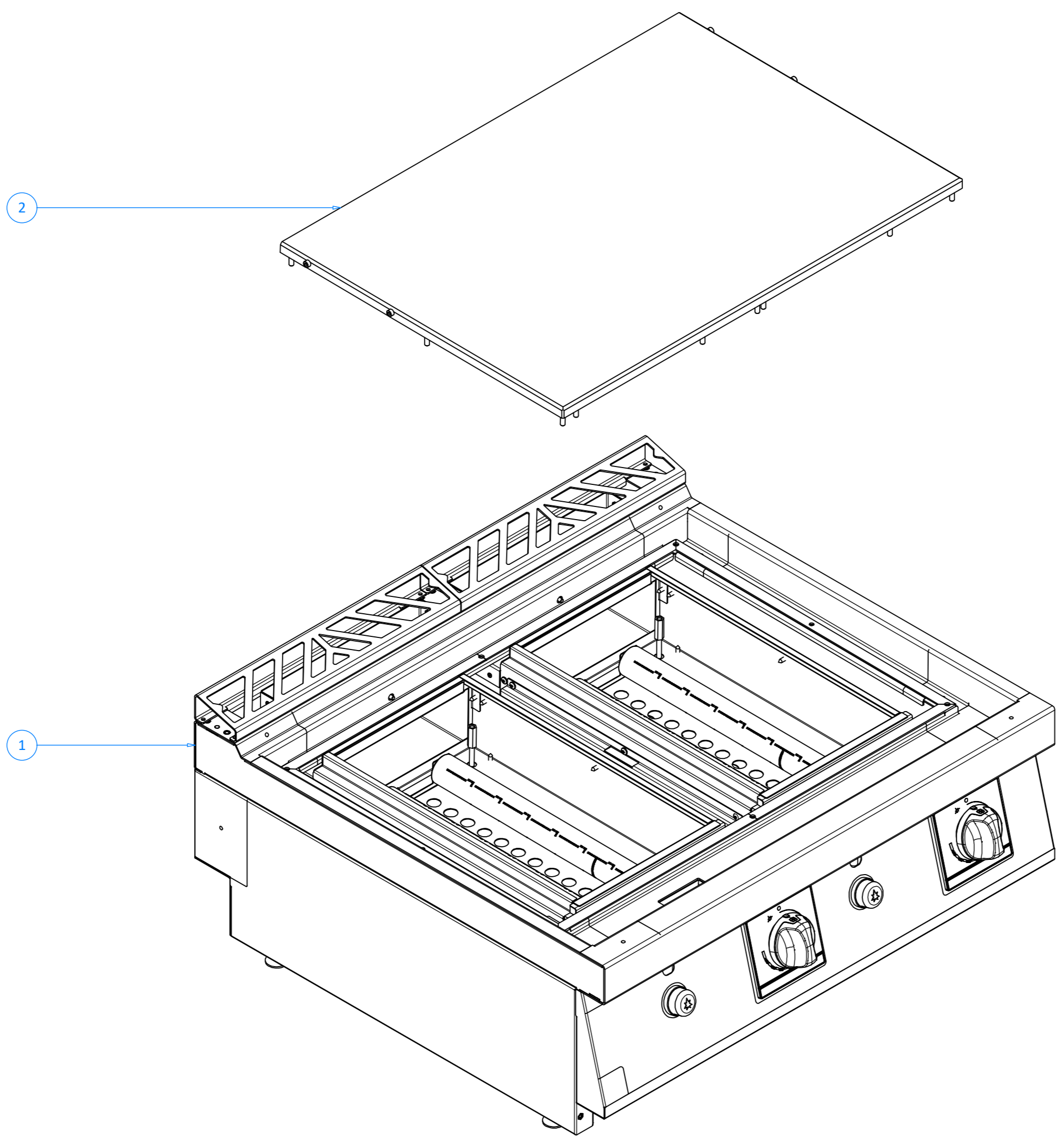

PROGETTO DI:		DANILO.GIAMMARUCO			
DISEGNATO DA:		DANILO.GIAMMARUCO			
MATERIALE					
		FOGLIO	SCALA		PESO IN KG
		A2	1 : 5		
CODICE	REV.	DESCRIZIONE			
10372022	00	M7TFGXXX GAS FRY-TOP TOP 800x730			

A B C D E F G H I L M N

A B C D E F G H I L M N

				ELENCO PARTI								
N°	QTÀ	CODICE	REV.	DESCRIZIONE (ITA)	DESCRIPTION (EN)	BESCHREIBUNG (DE)	DESCRIPTION (FR)	DESCRIPCIÓN (ES)				
1	1	20100634	00	ASS. FRYTOP TOP 80X70 GAS MASTER								
2	1	20100286	00	ASS. PIASTRA LC FRYTOP 80X70 MILO								



PROGETTO DI:											
DISEGNATO DA:		DANILO.GIAMMARUCO									
MATERIALE											
		FOGLIO	SCALA			TOLLERANZE GENERALI		PESO IN KG			
		A2				ISO 2768-1 mK					
CODICE		REV.	DESCRIZIONE								
			M7TFGXXX GAS FRY-TOP TOP 800x730								

A B C D E F G H I L M N

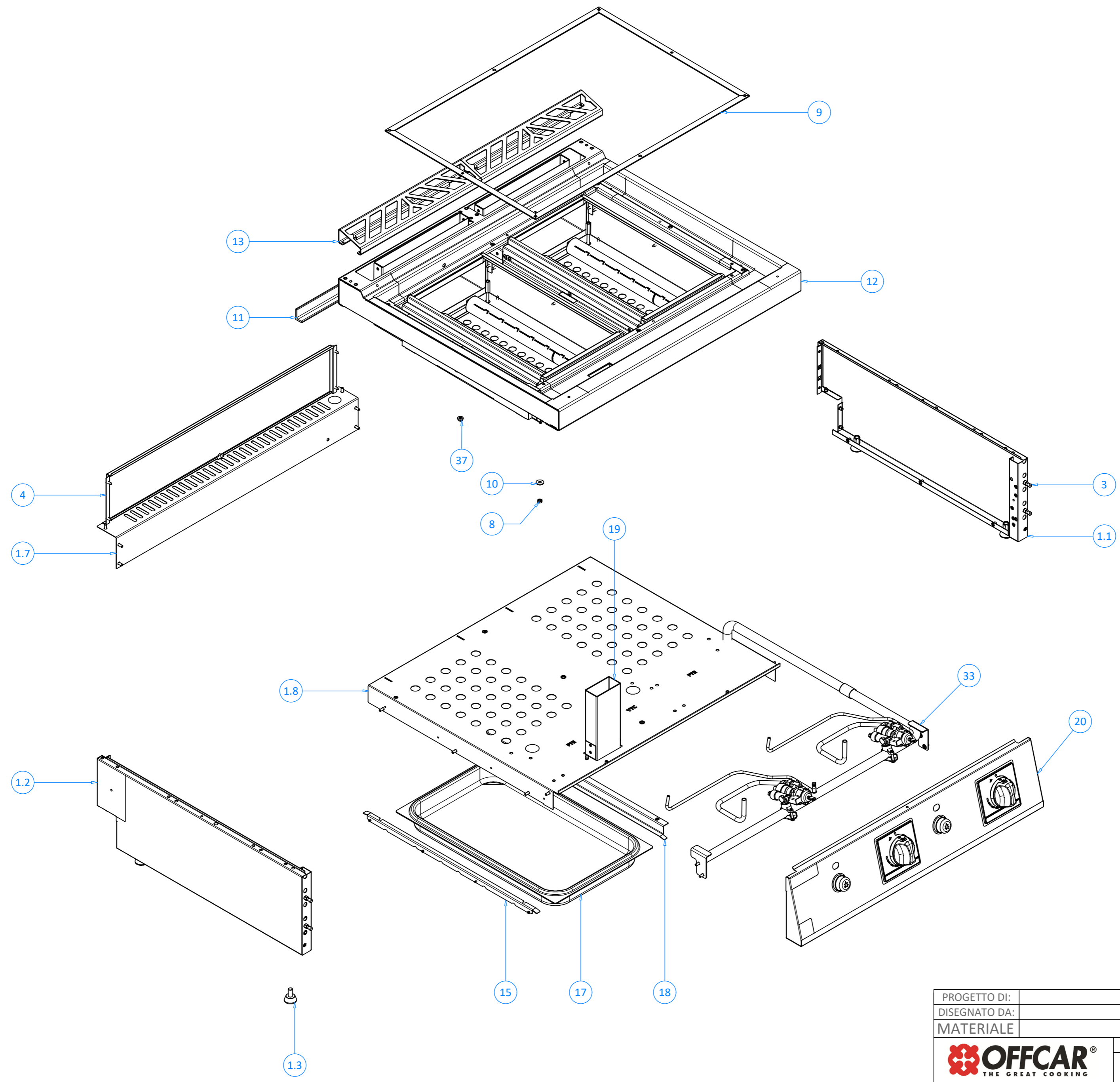

PROGETTO DI:		DANILO.GIAMMARUCO			
DISEGNATO DA:		DANILO.GIAMMARUCO			
MATERIALE		FOGLIO	SCALA	TOLLERANZE GENERALI	PESO IN KG
OFFCAR® THE GREAT COOKING		A2	1 : 7	ISO 2768-1 mK	42.28
CODICE	REV.	DESCRIZIONE			
20100634	00	M7TFGXXX GAS FRY-TOP TOP 800x730			

A		B		C		D		E		F		G		H		I		L		M		N			
ELENCO PARTI																									
N°	QTÀ	CODICE		REV.	DESCRIZIONE (ITA)	DESCRIPTION (EN)						BESCHREIBUNG (DE)						DESCRIPTION (FR)				DESCRIPCIÓN (ES)			
1.1	1	60200975		08	FIANCO DX SERIE 70 TOP - MILO																				
1.2	1	60200978		08	FIANCO SX SERIE 70 TOP - MILO																				
1.3	4	844345		00	PIEDINO REG.POLI.NERO 30XM10 40152N																				
1.7	1	60201091		04	ANGOL. CHIUSURA POST. TOP S7 800																				
1.8	1	60201090		07	PROT. INF FRYT/VTC TOP - S7 800																				
3	4	829541		00	MANIGLIETTE FE/ZN 9X34XM5 CRUS																				
4	1	60201092		02	SCHIENA RINFORZATA 800 TOP MILO																				
8	8	853671		00	DADO INOX M6 DIN 934																				
9	1	20100478		00	ASS. KIT GUARNIZIONI PIASTRA 80X70																				
10	10	853793		00	ROSETTA INOX M6 6X18 UNI6593 (GREM)																				
11	1	80300530		01	PROFILO L RINFORZO FRYTOP 800 MILO																				
12	1	20400019		03	EST. SAL. TEL. FRY-TOP 800X730 MILO																				
13	2	20400044		03	VERN. PROLUNGA CAMINO PER ALZ. 400																				
15	1	60200052		04	FINITO PROFILO GUIDA VASCA RAC																				
17	1	897115		00	BACINELLA INOX GN 1/1 325X530X40H																				
18	1	60201689		02	GUIDA TEGLIA GN 1/1 FRYTOP TOP																				
19	1	20100594		00	ASS. SCARICO FRYTOP MILO																				
20	1	20100295		02	ASS. CRUSCOTTO FRYTOP GAS 800 MILO																				
33	1	20100649		00	ASS. PREASS. DISTR. FRYTOP TOP 800																				
37	8	853660		00	DADO FLANG. ZIGRIN. 6923 M6 ZN																				



PROGETTO DI:											
DISEGNATO DA:		DANILO.GIAMMARUCO									
MATERIALE											
		FOGLIO	SCALA		TOLLERANZE GENERALI	PESO IN KG					
		A2			ISO 2768-1 mK						
CODICE		REV.	DESCRIZIONE								
			M7TFGXXX GAS FRY-TOP TOP 800x730								

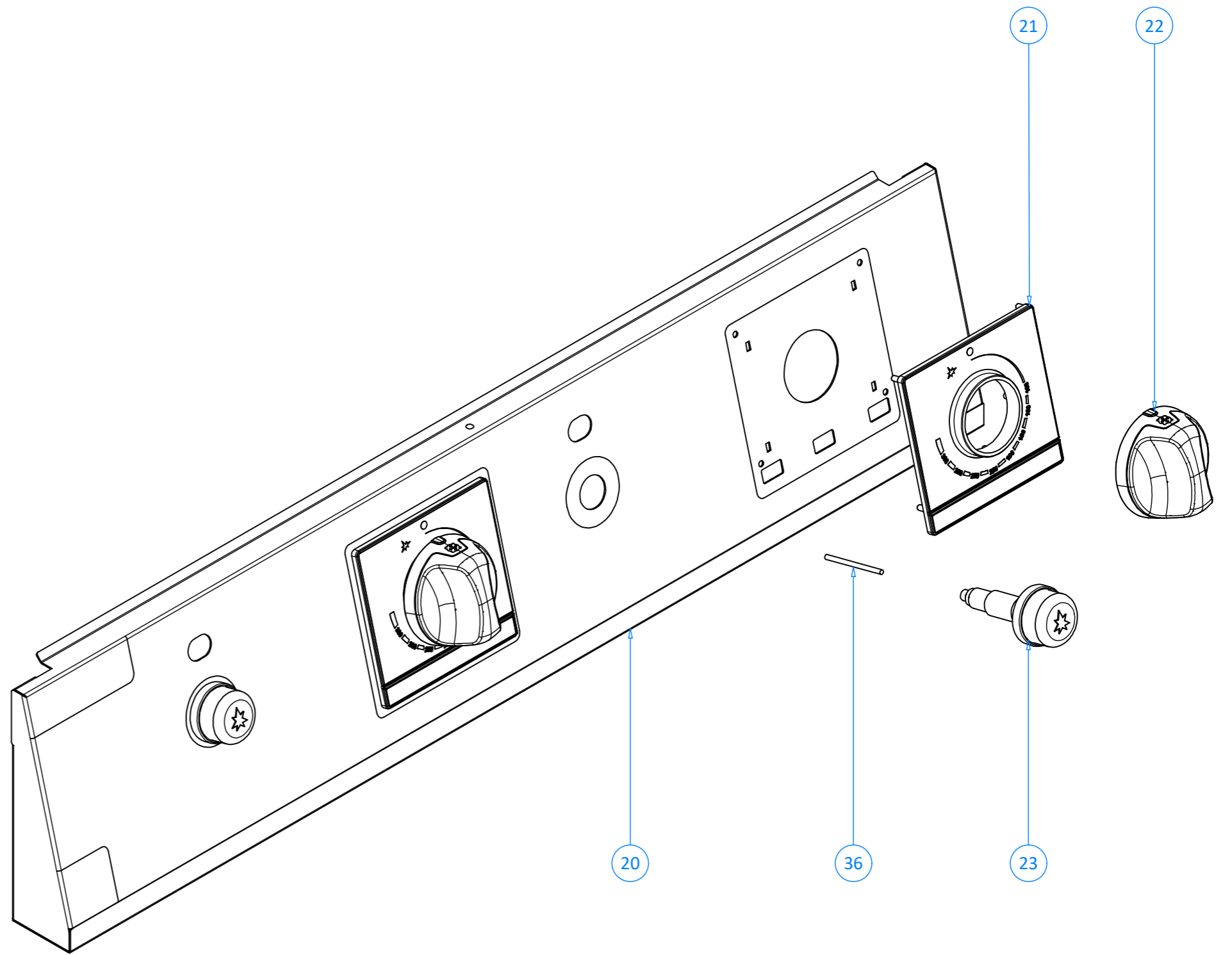
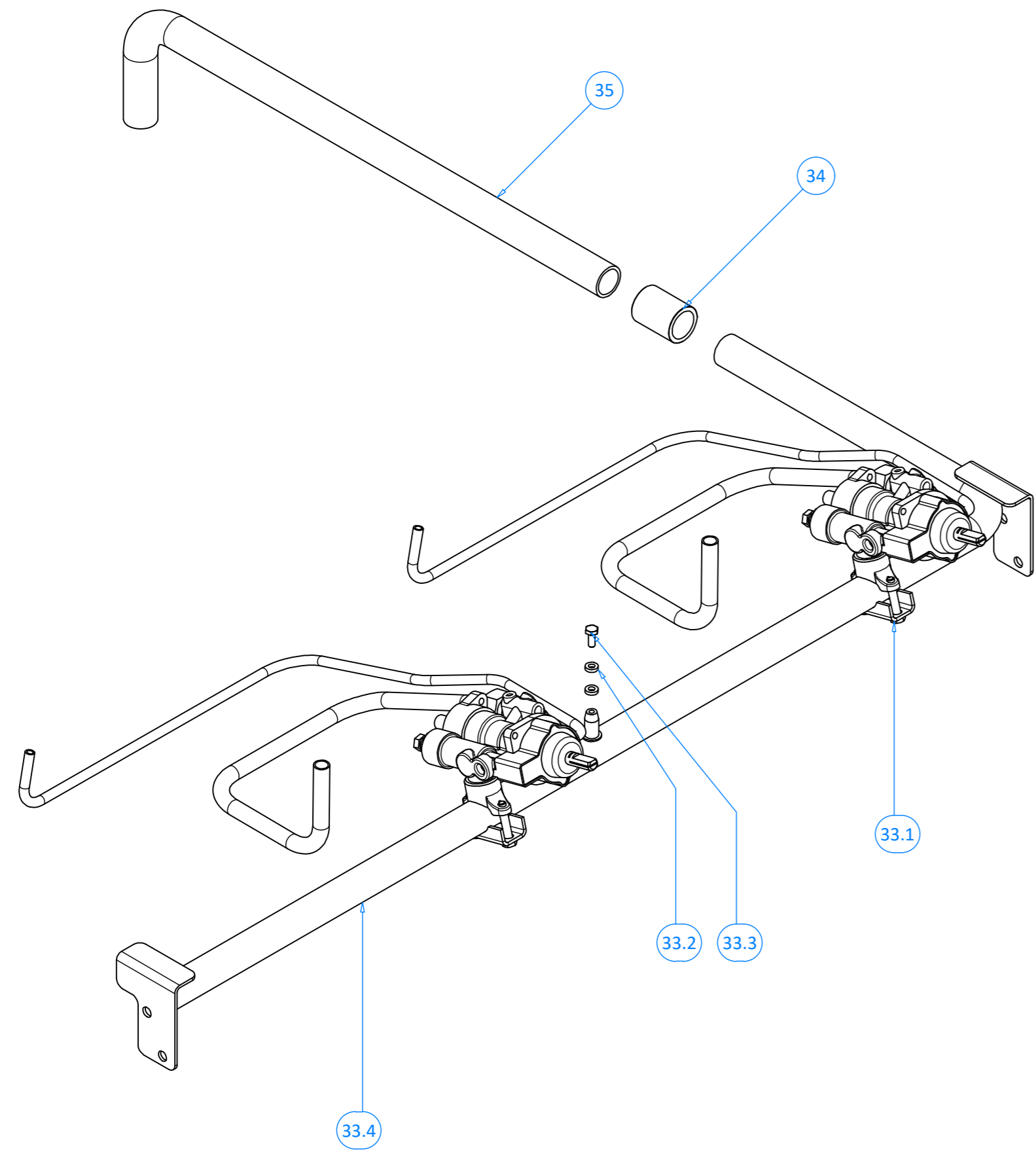

PROGETTO DI:	DANILO.GIAMMARUCO			
DISEGNATO DA:	DANILO.GIAMMARUCO			
MATERIALE	FOGLIO	SCALA	TOLLERANZE GENERALI	PESO IN KG
	A2	1 : 3	ISO 2768-1 mK	42.28
CODICE	REV.	DESCRIZIONE		
20100634	00	M7TFGXXX GAS FRY-TOP TOP 800x730		

				ELENCO PARTI				
N°	QTÀ	CODICE	REV.	DESCRIZIONE (ITA)	DESCRIPTION (EN)	BESCHREIBUNG (DE)	DESCRIPTION (FR)	DESCRIPCIÓN (ES)
20	1	20100295	02	ASS. CRUSCOTTO FRYTOP GAS 800 MILO				
21	2	80300133	00	GHIERA FRY-TOP MILO GAS 100/300°				
22	2	80300097	02	MANOPOLA MILO GAS D.8 25ST				
23	2	835926	00	ACCENSIONE PIEZOEL. FILETT. M22X1,5				
33.1	2	401261	00	RUBIN.GAS COLL.COMP.RACC.25ST S7/9S				
33.2	2	853994	00	RONDELLA RAME 4X8X2				
33.3	1	852491	00	VITE TE INOX FINTA ROND. M4X10				
33.4	1	20100586	01	ASS. DISTR. FRYTOP 800 MILO UN. LAV				
34	1	829420	00	MANICOTTO INOX316 1/2 L.32 ART.270				
35	1	80300643	01	TUBO USCITA GAS MACCHINE TOP S7				
36	2	835909	00	CAVO X PIEZOEL.COLL. CM.50				

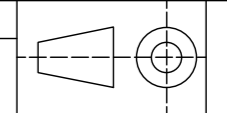

PROGETTO DI:						
DISEGNATO DA:		DANILO.GIAMMARUCO				
MATERIALE						
	FOGLIO	SCALA		TOLLERANZE GENERALI ISO 2768-1 mK	PESO IN KG	
	A2					
CODICE	REV.	DESCRIZIONE				
		M7TFGXXX GAS FRY-TOP TOP 800x730				



A B C D E F G H I L M N

1  
2  
3  
4  
5  
6  
7  
8

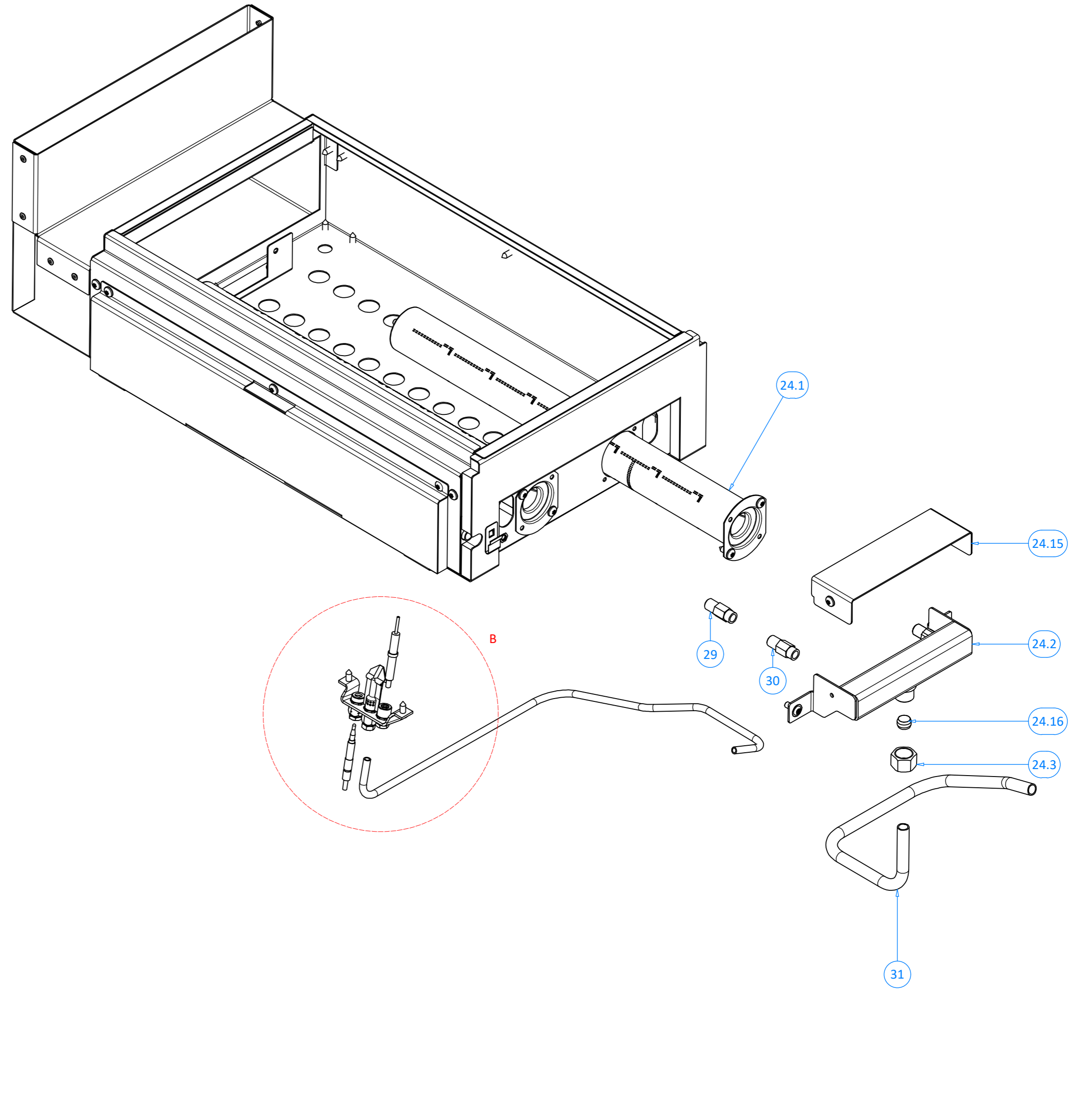

PARTICOLARE B

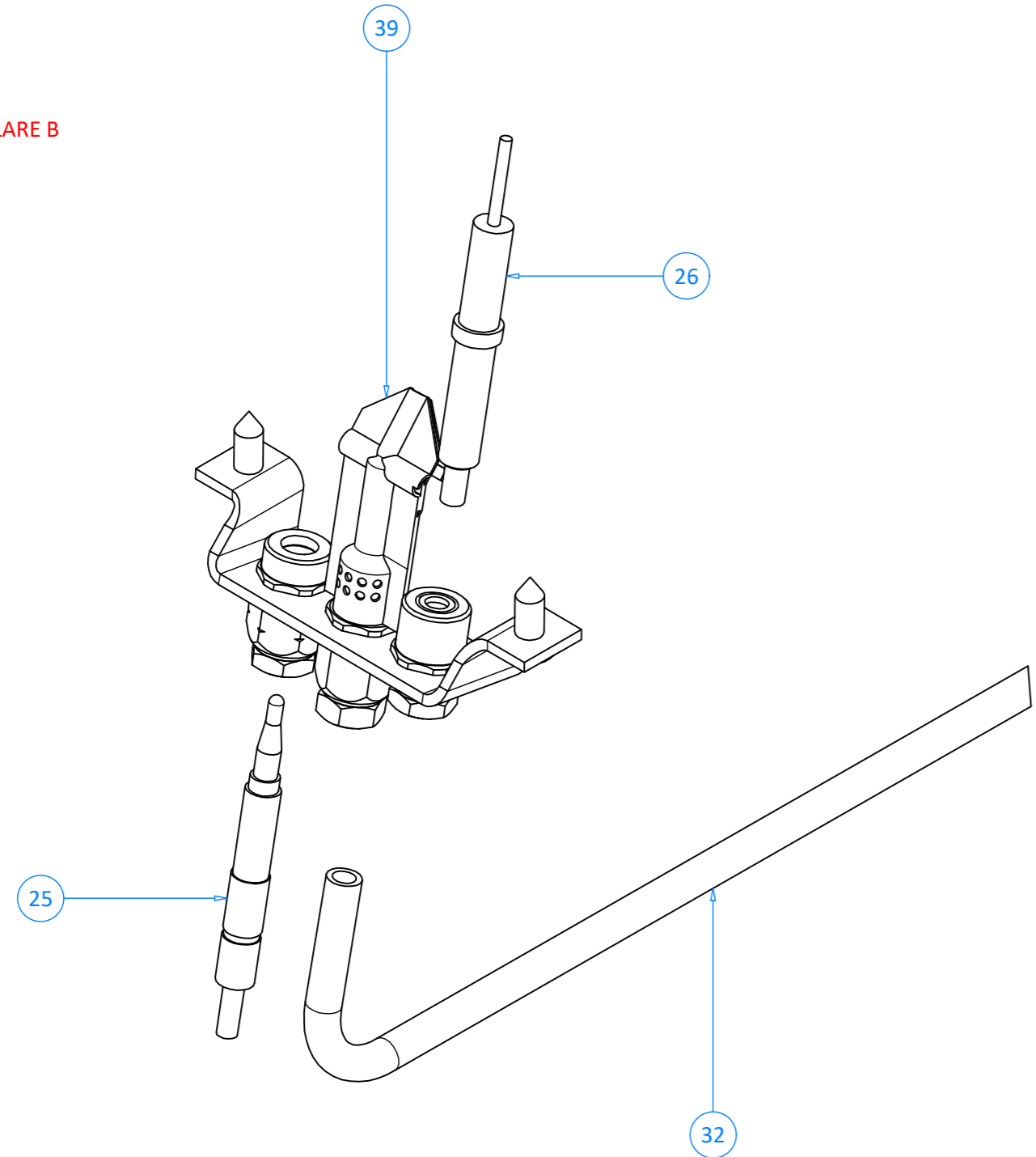

PROGETTO DI:	DANILO.GIAMMARUCO			
DISEGNATO DA:	DANILO.GIAMMARUCO			
MATERIALE	FOGLIO	SCALA	TOLLERANZE GENERALI	PESO IN KG
	A2	1 : 3	ISO 2768-1 mK	42.28
CODICE	REV.	DESCRIZIONE		
20100634	00	M7TFGXXX GAS FRY-TOP TOP 800x730		

A B C D E F G H I L M N

A		B		C		D		E		F		G		H		I		L		M		N	
N°	QTÀ	CODICE		REV.	DESCRIZIONE (ITA)	DESCRIPTION (EN)		BESCHREIBUNG (DE)		DESCRIPTION (FR)		DESCRIPCIÓN (ES)											
24.1	4	841255		00	BRUCIATORE FRY-TOP S.70 102.0967.00																		
24.2	2	832851		04	COLLETTORE 2 UGELLI X FRY-TOP S.7/9																		
24.3	2	835313		00	DADO M16X1,5 F.10X RUBIN S.7 0907/6																		
24.15	2	60201660		02	STAFFA COPRI COLLETTORE FRYTOP MILO																		
24.16	2	835321		00	BICONO DIAM.10 0905/2 S.700																		
25	2	837243		00	TERMOCOPPIA QUICK DA 600 0290016																		
26	2	835915		00	ELETTRODO ACCENS. PIEZO 031.0014.00																		
29	4	8293505		00	UGELLO OTT.CH12X30 M10X1 F.0,95*95																		
30	4	8293647		00	UGELLO OT.CH12X30 M10X1 F.1,40*140R																		
31	2	80300304		01	TUBO D.10 FRYTOP GAS MILO																		
32	2	80300305		01	TUBO PILOTA D.6 FRYTOP MILO																		
39	2	403121		00	BRUCIAT.PIL.3 VIE COMP.RACC.FRY-TOP																		

ELENCO PARTI

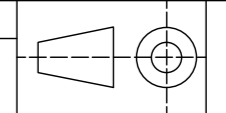
PROGETTO DI:											
DISEGNATO DA:		DANILO.GIAMMARUCO									
MATERIALE											
		FOGLIO	SCALA			TOLLERANZE GENERALI		PESO IN KG			
		A2				ISO 2768-1 mK					
CODICE		REV.	DESCRIZIONE								
			M7TFGXXX GAS FRY-TOP TOP 800x730								