

SEZIONE A - A

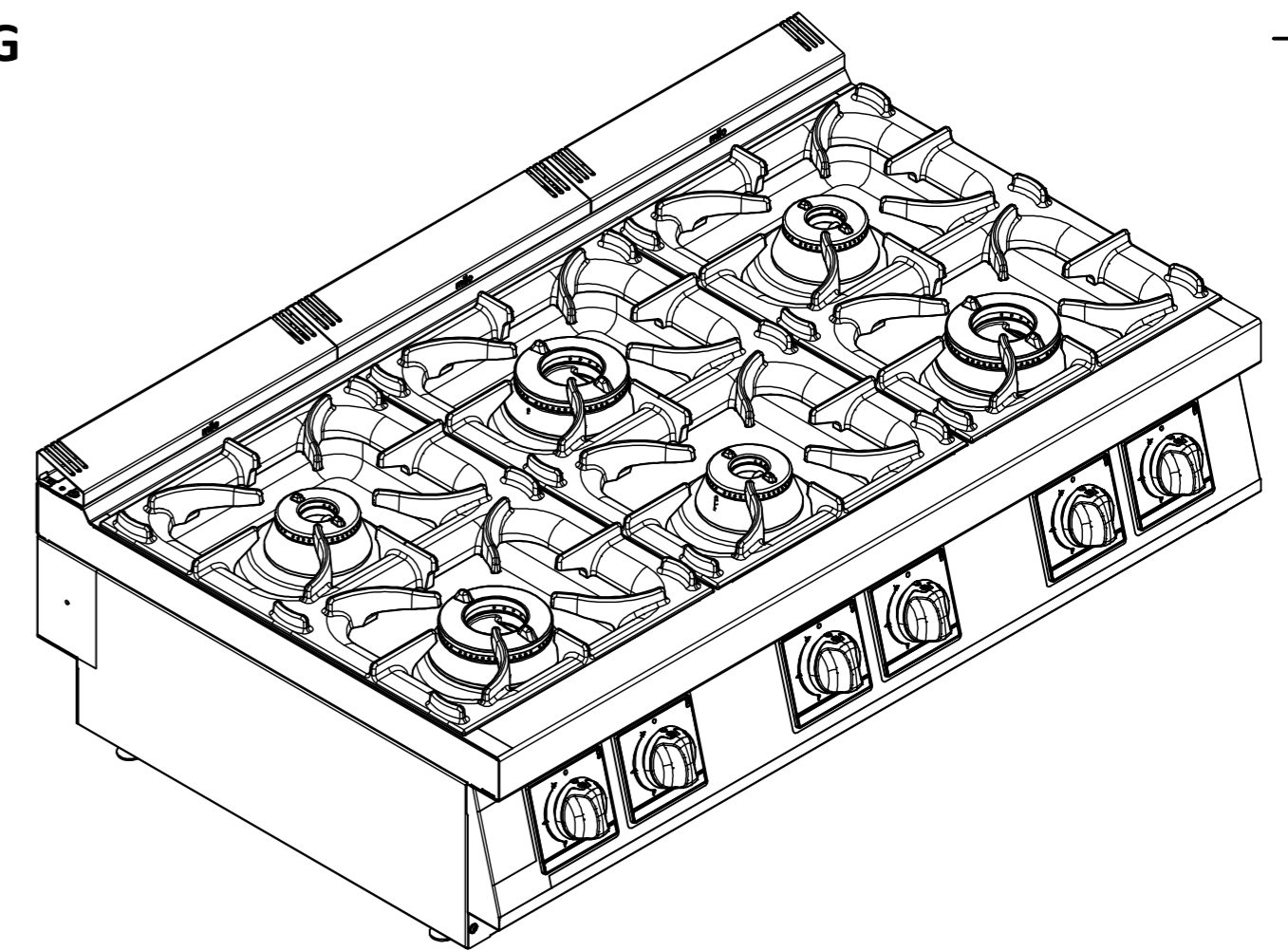
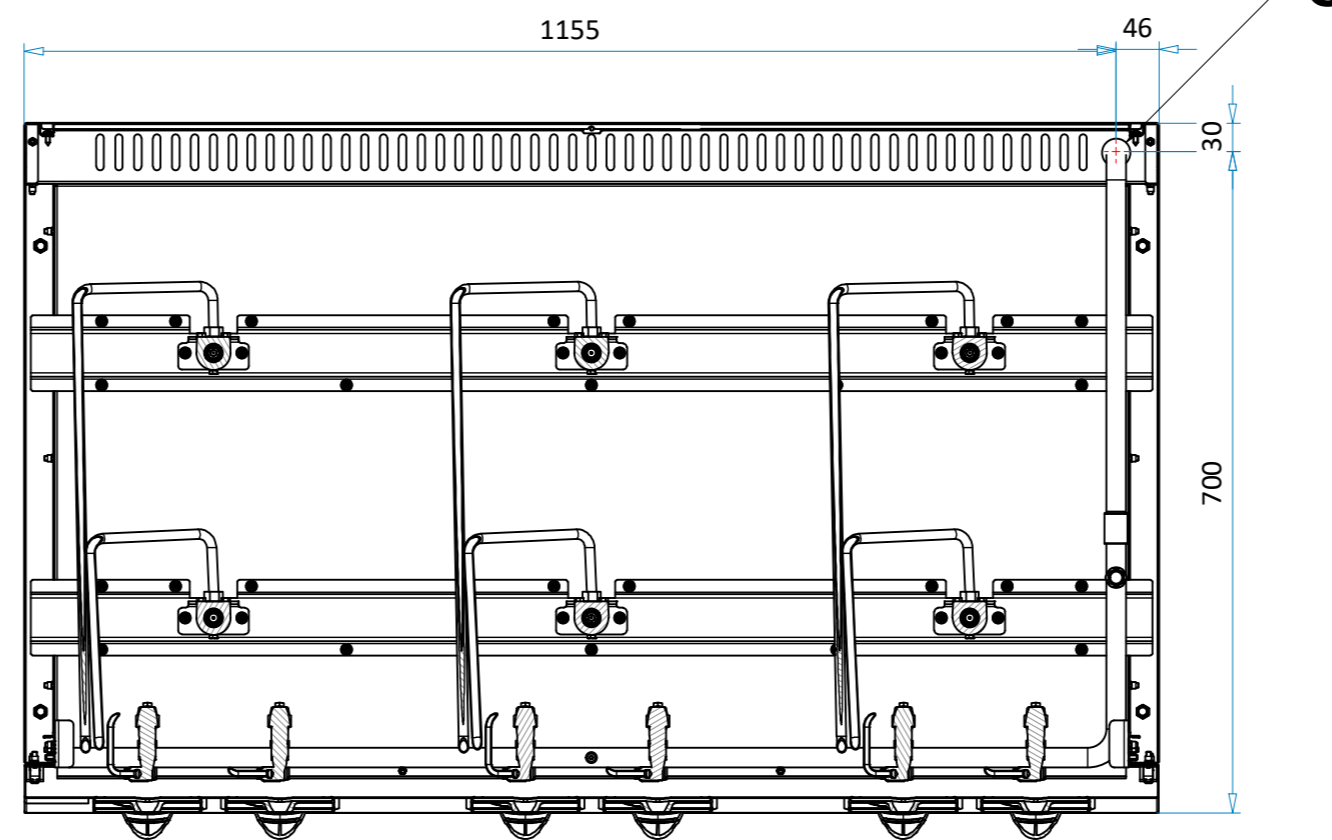
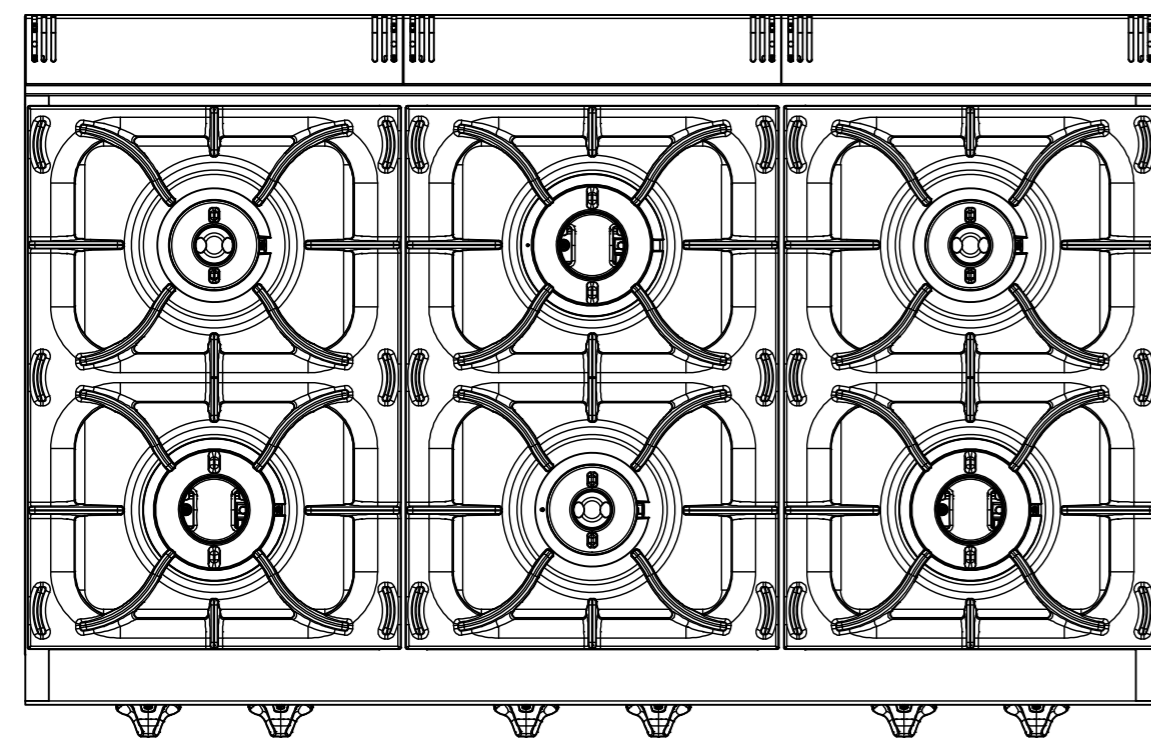

REV.	DESCRIZIONE	APPROVATO DA	DATA
00	Emesso	VLADUT.IACOMI	27/02/2025
PROGETTO DI:		DANILO.GIAMMARUCO	
DISEGNATO DA:		DANILO.GIAMMARUCO	
MATERIALE			
		FOGLIO A2	SCALA 1 : 8
			TOLLERANZE GENERALI ISO 2768-1 mK
			PESO IN KG 76.91
CODICE	REV.	DESCRIZIONE	
10172028	00	M7TCG6 CUCINA GAS 6B.DOP.COR.	

A		B		C		D		E		F		G		H		I		L		M		N							
ELENCO PARTI																													
N°	QTÀ	CODICE		REV.	DESCRIZIONE (ITA)	DESCRIPTION (EN)						BESCHREIBUNG (DE)						DESCRIPTION (FR)						DESCRIPCIÓN (ES)					
1	1	20100604		00	ASS. MANTELLO CUCINA S70 - 1200 TOP																								
2	52	80300259		00	VITE TB TX25 FLANG.A2 INOX M5X12																								
3	4	829541		00	MANIGLIETTE FE/ZN 9X34XM5 CRUS																								
4	1	60201560		03	SCHIENA RINFORZATA 1200 TOP MILO																								
5	4	80300260		00	VITE AUTOFIL. DIN 7981/TX 4,8X13 ZNC																								
6	3	60200928		04	COPERTURA FORO PIANO MILO - 400																								
7	1	20300012		00	IMBALLO 1200 MILO TOP																								
8	1	20100398		00	ASS. CRUSCOTTO CUCINA 6F MILO MG																								
9	3	80300125		00	GHIERA MACCHINE MILO GAS POSTERIORE																								
10	6	80300098		02	MANOPOLA MILO GAS D.8																								
11	3	80300124		00	GHIERA MACCHINE MILO GAS ANTERIORE																								
12	1	20200138		02	SAL. TELAIO 120X70 CBG MILO																								
13	3	20100660		00	ASS. GRUPPO GAS MILO 7,5 KW																								
14	3	440109		00	GRIGLIA VET.2F. S.70 575X395 GV-700																								
15	3	20100584		00	ASS. GRUPPO GAS MILO 4.5 KW																								
16	3	20300018		00	BAC. SOTTOS. S7 FORATA DC - SBAV.																								
17	3	837243		00	TERMOCOPPIA QUICK DA 600 0290016																								
18	3	837233		00	TERMOCOPPIA QUICK DA 320 0290012																								
19	2	60201302		00	OMEGA SUPPORTO BRUC. 6F CBG - S7																								
20	12	80300258		00	INSERTO M5 ESAGONO ZINCATO																								
21	1	829420		00	MANICOTTO INOX316 1/2 L.32 ART.270																								
22	1	20100663		00	ASS. PREASS. DISTRIB. TCG 6F MILO																								
23	1	80300643		01	TUBO USCITA GAS MACCHINE TOP S7																								
24	3	817361		02	TUBO GAS 10 BRUC.ANT. L. S.700S																								
25	3	817371		02	TUBO GAS 10 BRUC.POST.L.70S-EVO 700																								
26	3	817341		02	TUBO GAS 6 PIL.POST. S.700S																								
27	3	8173011		05	TUBO GAS 6 PIL. ANT. S.70/S.90 EVO																								
28	1	80300138		00	LOGO OFFCAR 36X36 METAL THIN LABEL																								
29	1	20300024		00	KIT GIUNZIONE MACCHINE																								
30	1	60201839		00	CHIUS. ANTERIORE MACCHINE TOP 1200																								
31	1	830151		00	TAPPO FEMMINA ZINC. 3/8 300-Z 3/8																								

PROGETTO DI:	DANILO.GIAMMARUCO										
DISEGNATO DA:	DANILO.GIAMMARUCO										
MATERIALE											
	FOGLIO	SCALA		TOLLERANZE GENERALI ISO 2768-1 mK	PESO IN KG						
	A2	1 : 8			76.91						
CODICE	REV.	DESCRIZIONE									
10172028	00	M7TCG6 CUCINA GAS 6B.DOP.COR.									

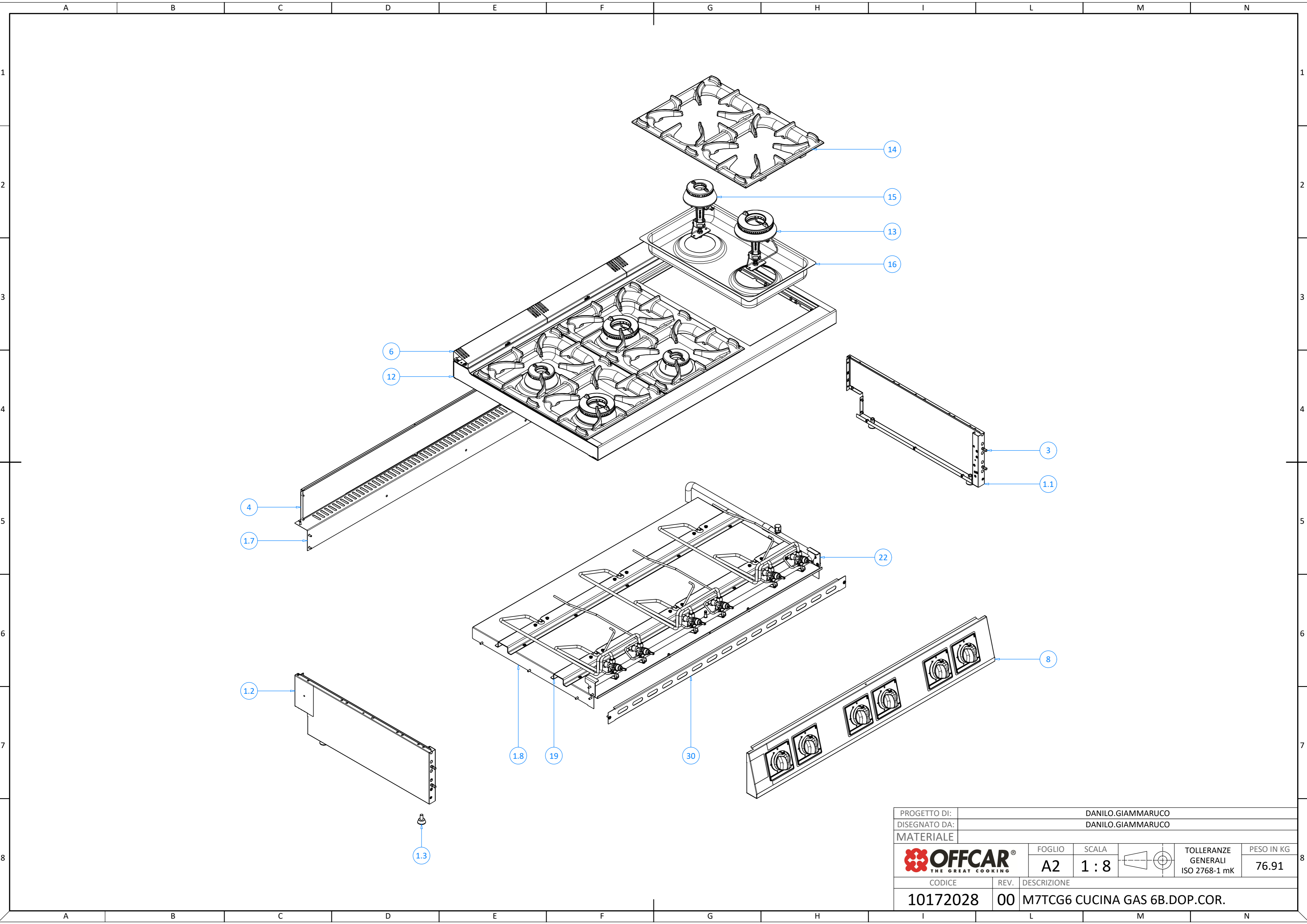

PROGETTO DI:	DANILO.GIAMMARUCO			
DISEGNATO DA:	DANILO.GIAMMARUCO			
MATERIALE	FOGLIO	SCALA	TOLLERANZE GENERALI	PESO IN KG
OFFCAR THE GREAT COOKING	A2	1 : 8	ISO 2768-1 mK	76.91
CODICE	REV.	DESCRIZIONE		
10172028	00	M7TCG6 CUCINA GAS 6B.DOP.COR.		

A		B		C		D		E		F		G		H		I		L		M		N	
N°	QTÀ	CODICE		REV.	DESCRIZIONE (ITA)	ELENCO PARTI						DESCRIPTION (FR)		DESCRIPCIÓN (ES)									
					DESCRIPTION (EN)	BESCHREIBUNG (DE)																	
1	1	20100604		00	ASS. MANTELLO CUCINA S70 - 1200 TOP																		
1.1	1	60200975		08	FIANCO DX SERIE 70 TOP - MILO																		
1.2	1	60200978		08	FIANCO SX SERIE 70 TOP - MILO																		
1.3	4	844345		00	PIEDINO REG.POLI.NERO 30XM10 40152N																		
1.7	1	60201559		03	ANGOL. CHIUSURA POST. TOP S7 1200																		
1.8	1	60201746		01	PROT. INFER. CUCINA TOP - S7 1200																		
3	4	829541		00	MANIGLIETTE FE/ZN 9X34XM5 CRUS																		
4	1	60201560		03	SCHIENA RINFORZATA 1200 TOP MILO																		
6	3	60200928		04	COPERTURA FORO PIANO MILO - 400																		
12	1	20200138		02	SAL. TELAIO 120X70 CBG MILO																		
13	3	20100660		00	ASS. GRUPPO GAS MILO 7,5 KW																		
14	3	440109		00	GRIGLIA VET.2F. S.70 575X395 GV-700																		
15	3	20100584		00	ASS. GRUPPO GAS MILO 4.5 KW																		
16	3	20300018		00	BAC. SOTTOS. S7 FORATA DC - SBAV.																		
19	2	60201302		00	OMEGA SUPPORTO BRUC. 6F CBG - S7																		
22	1	20100663		00	ASS. PREASS. DISTRIB. TCG 6F MILO																		
30	1	60201839		00	CHIUS. ANTERIORE MACCHINE TOP 1200																		



PROGETTO DI:	DANILO.GIAMMARUCO				
DISEGNATO DA:	DANILO.GIAMMARUCO				
MATERIALE					
	FOGLIO	SCALA		TOLLERANZE GENERALI ISO 2768-1 mK	PESO IN KG
	A2	1 : 8			76.91
CODICE	REV.	DESCRIZIONE			
10172028	00	M7TCG6 CUCINA GAS 6B.DOP.COR.			

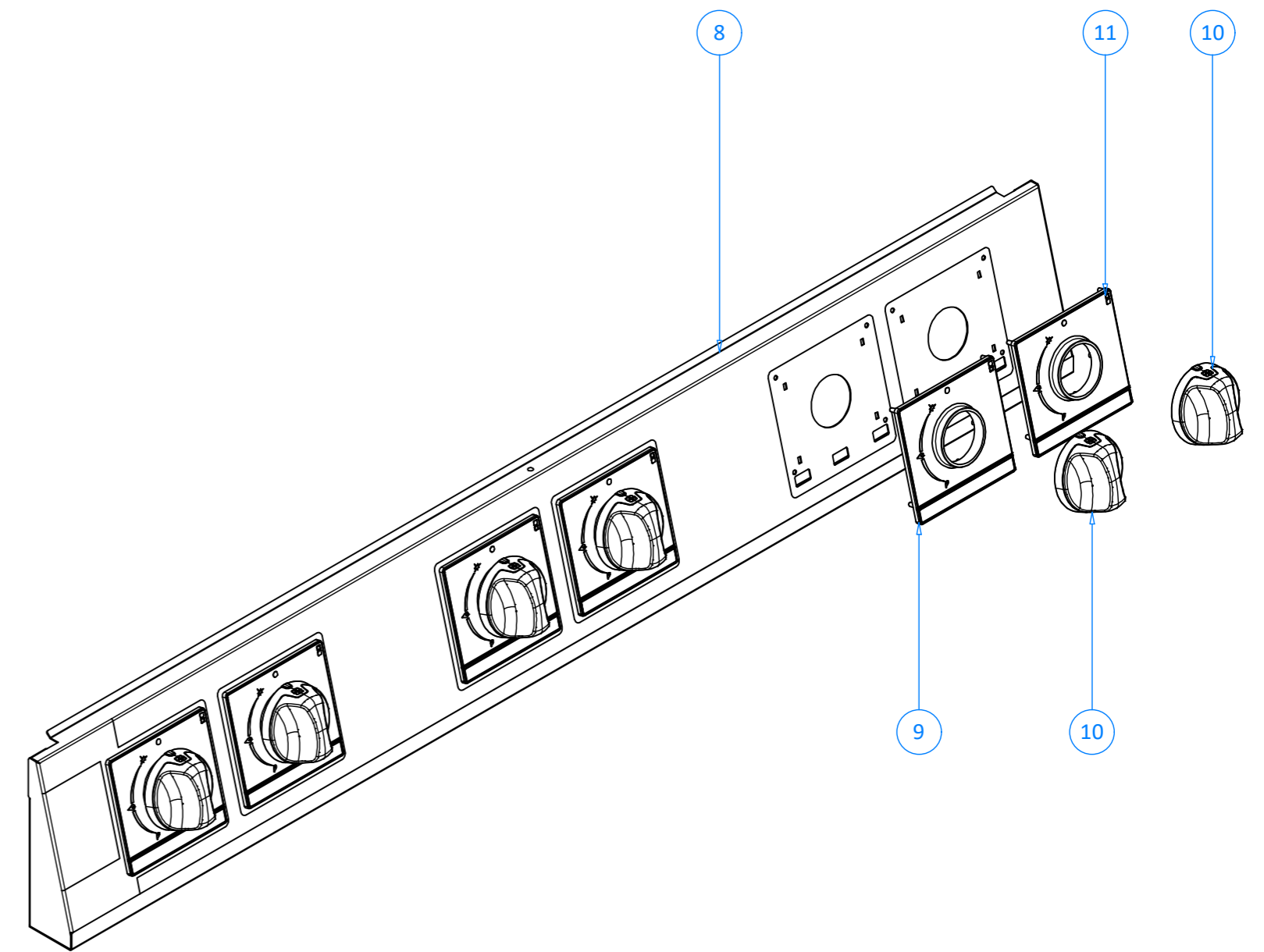
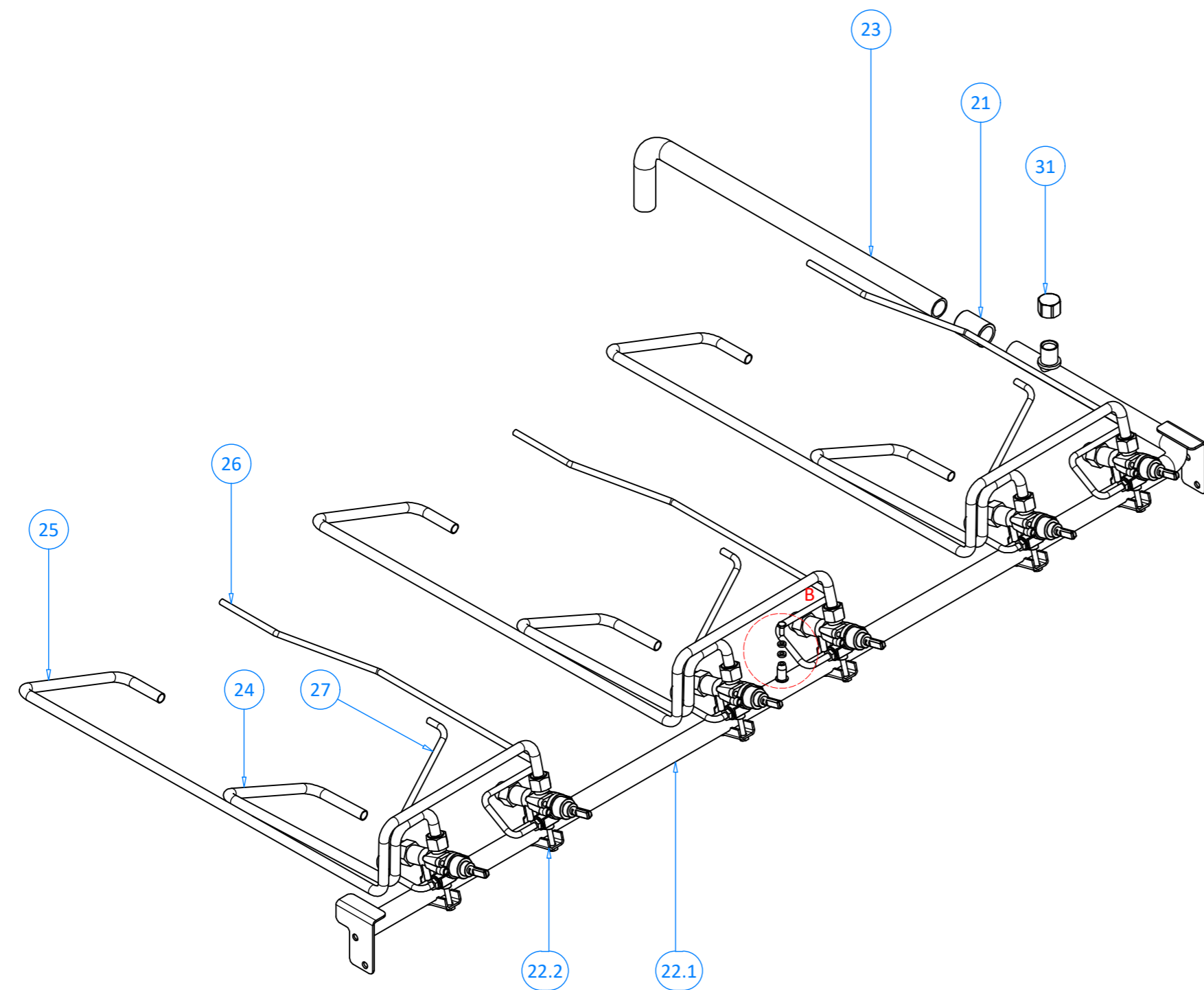

PARTICOLARE B

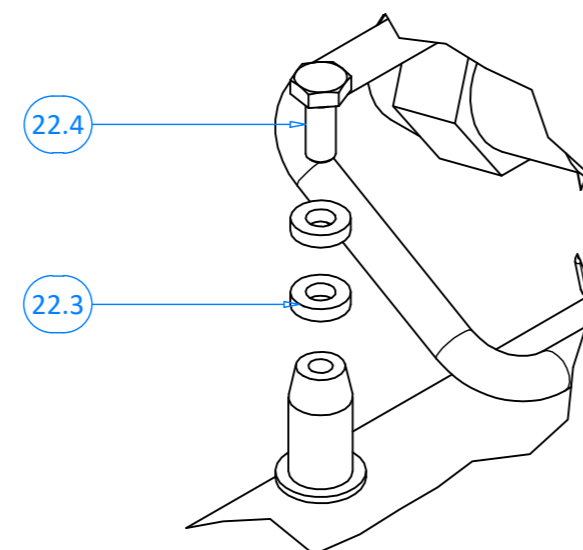

PROGETTO DI:	DANILO.GIAMMARUCO				
DISEGNATO DA:	DANILO.GIAMMARUCO				
MATERIALE	FOGLIO	SCALA	TOLLERANZE GENERALI	PESO IN KG	
	A2	1 : 5	ISO 2768-1 mK	76.91	
CODICE	REV.	DESCRIZIONE			
10172028	00	M7TCG6 CUCINA GAS 6B.DOP.COR.			

				ELENCO PARTI				
N°	QTÀ	CODICE	REV.	DESCRIZIONE (ITA)	DESCRIPTION (EN)	BESCHREIBUNG (DE)	DESCRIPTION (FR)	DESCRIPCIÓN (ES)
8	1	20100398	00	ASS. CRUSCOTTO CUCINA 6F MILO MG				
9	3	80300125	00	GHIERA MACCHINE MILO GAS POSTERIORE				
10	6	80300098	02	MANOPOLA MILO GAS D.8				
11	3	80300124	00	GHIERA MACCHINE MILO GAS ANTERIORE				
21	1	829420	00	MANICOTTO INOX316 1/2 L.32 ART.270				
23	1	80300643	01	TUBO USCITA GAS MACCHINE TOP S7				
24	3	817361	02	TUBO GAS 10 BRUC.ANT. L. S.700S				
25	3	817371	02	TUBO GAS 10 BRUC.POST.L.70S-EVO 700				
26	3	817341	02	TUBO GAS 6 PIL.POST. S.700S				
27	3	8173011	05	TUBO GAS 6 PIL. ANT. S.70/S.90 EVO				
31	1	830151	00	TAPPO FEMMINA ZINC. 3/8 300-Z 3/8				



PROGETTO DI:	DANILO.GIAMMARUCO				
DISEGNATO DA:	DANILO.GIAMMARUCO				
MATERIALE					
	FOGLIO	SCALA		TOLLERANZE GENERALI ISO 2768-1 mK	PESO IN KG
	A2	1 : 8			
CODICE	REV.	DESCRIZIONE			
10172028	00	M7TCG6 CUCINA GAS 6B.DOP.COR.			

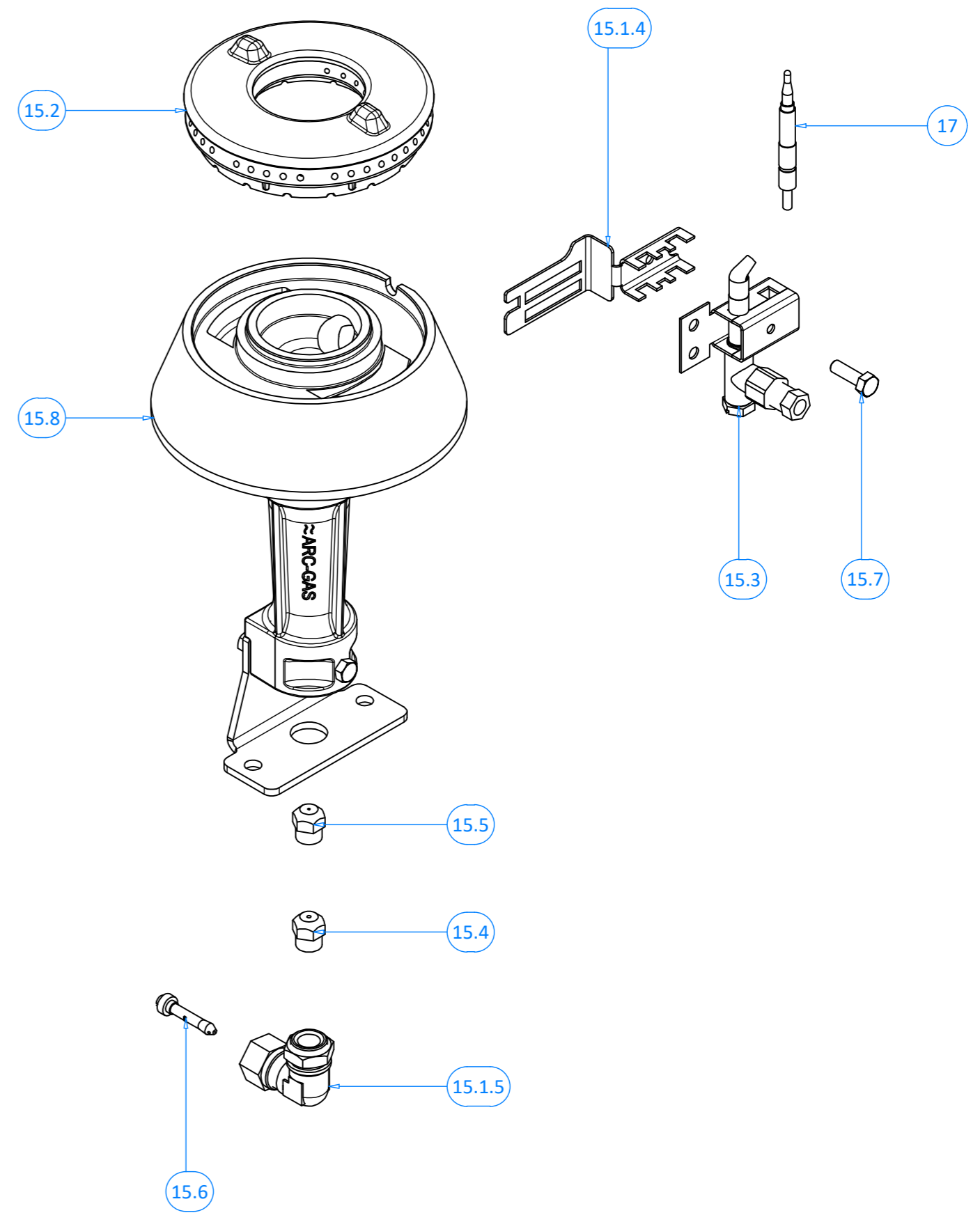
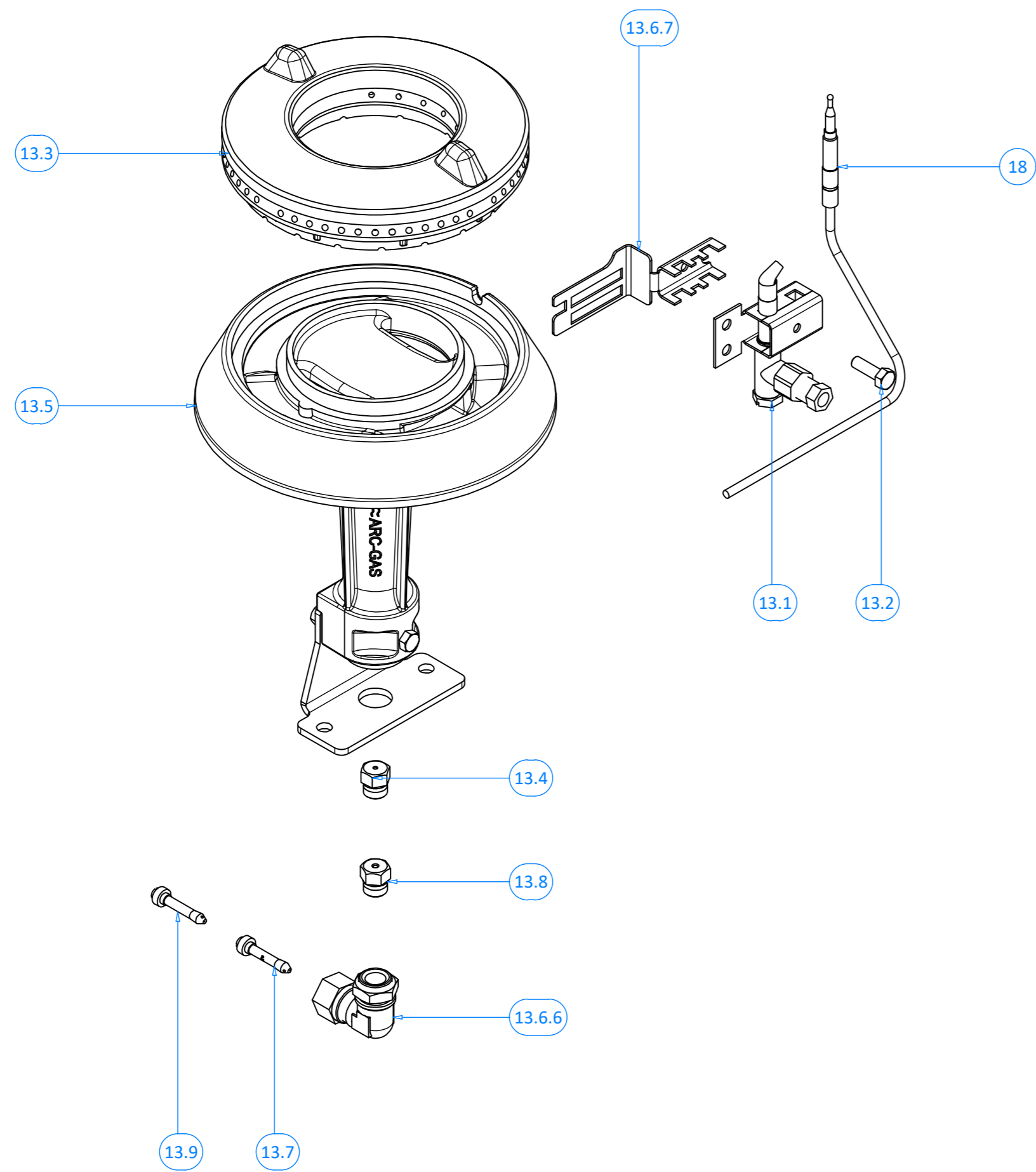

PROGETTO DI:	DANILO.GIAMMARUCO			
DISEGNATO DA:	DANILO.GIAMMARUCO			
MATERIALE	FOGLIO	SCALA	TOLLERANZE GENERALI	PESO IN KG
	A2	1 : 2	ISO 2768-1 mK	76.91
CODICE	REV.	DESCRIZIONE		
10172028	00	M7TCG6 CUCINA GAS 6B.DOP.COR.		

A		B		C		D		E		F		G		H		I		L		M		N		
ELENCO PARTI																								
N°	QTÀ	CODICE		REV.	DESCRIZIONE (ITA)				DESCRIPTION (EN)				BESCHREIBUNG (DE)				DESCRIPTION (FR)				DESCRIPCIÓN (ES)			
13.1	3	837201		00	PILOTA 1 VIA MULTIGAS 0100013																			
13.2	3	852045		00	VITE TE INOX M5*16 DIN933																			
13.3	3	828139		00	SPARTIFIAMMA OT.DOPPIA C.128																			
13.4	3	829323		00	UGELLO M10X1 DIAM 1,30 65.J130																			
13.5	3	827359		00	CORPO BRUC.RE VETRI.DOP.C. 128																			
13.6.6	3	839347		00	PORTAUG. RIB. D.10 SERIE 65 65.RUN2																			
13.6.7	3	60201656		03	SQUADRETTA FISSAGGIO PILOTA																			
13.7	3	837281		00	UGELLO GAS MET.DIAM.0,35 * 0977031																			
13.8	3	829322		00	UGELLO ESAG.11 M10X1 Ø0,205 65.J205																			
13.9	3	837297		00	UGELLO GAS GPL DIAM.0,20 * 0977030																			
15.1.4	3	60201656		03	SQUADRETTA FISSAGGIO PILOTA																			
15.1.5	3	839347		00	PORTAUG. RIB. D.10 SERIE 65 65.RUN2																			
15.2	3	80300358		00	SPARTIFIAMMA OT.DOPPIA C.96 MILO																			
15.3	3	837201		00	PILOTA 1 VIA MULTIGAS 0100013																			
15.4	3	829333		00	UGELLO OTT.CH11X13 M10X1 F.1,55*155																			
15.5	3	829315		00	UGELLO OTT.CH11X13 M10X1 F.0,95*95																			
15.6	3	837281		00	UGELLO GAS MET.DIAM.0,35 * 0977031																			
15.7	3	852045		00	VITE TE INOX M5*16 DIN933																			
15.8	3	80300357		00	CORPO BRUC.RE VETRI.DOP.C. 96 MILO																			
17	3	837243		00	TERMOCOPPIA QUICK DA 600 0290016																			
18	3	837233		00	TERMOCOPPIA QUICK DA 320 0290012																			

PROGETTO DI:	DANILO.GIAMMARUCO									
DISEGNATO DA:	DANILO.GIAMMARUCO									
MATERIALE										
		FOGLIO	SCALA			TOLLERANZE GENERALI	PESO IN KG			
		A2	1 : 8			ISO 2768-1 mK	76.91			
CODICE	REV.	DESCRIZIONE								
10172028	00	M7TCG6 CUCINA GAS 6B.DOP.COR.								